

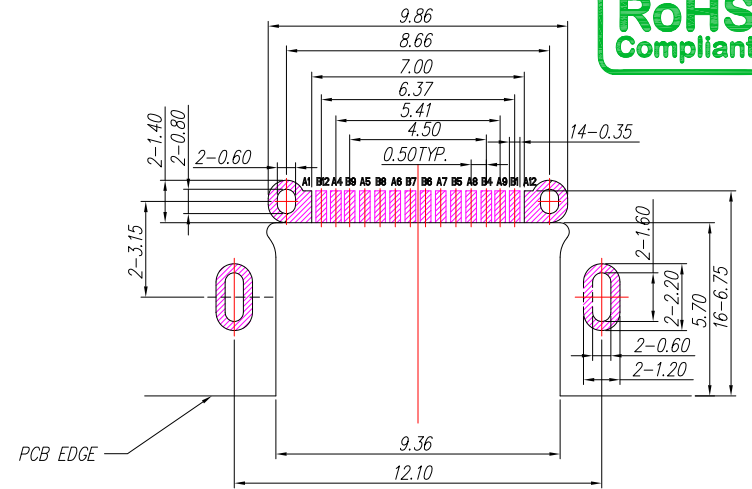

# SBC-160M25-20x-S165

鍍層厚度：

Blank : 1u"
2 : 15u"
3 : 30u"

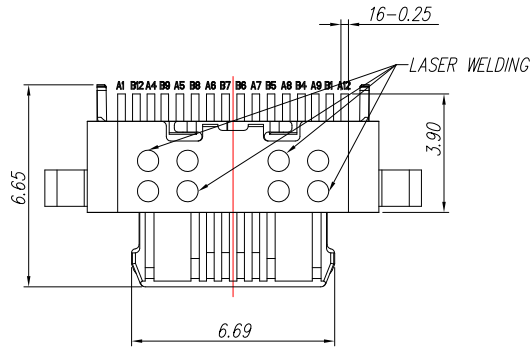

RECOMMENDED P.C.B. LAYOUT

PIN ASSIGNMENT												BLADE	SHELL
A1	A2	A3	A4	A5	A6	A7	A8	A9	A10	A11	A12		
GND	TX1	TX1	VBUS	CC1	D+	D-	SBU1	VBUS	RX2	RX2	GND	GND	GND
GND	RX1+	RX1-	VBUS	SBU2	D-	D+	CC2	VBUS	TX2-	TX2+	GND		
B12	B1	B10	B9	B8	B7	B6	B5	B4	B3	B2	B1		

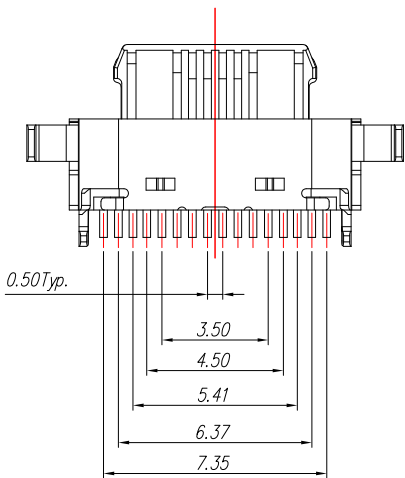
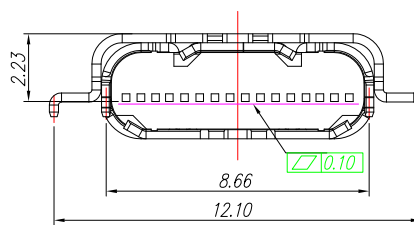
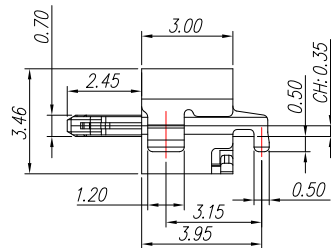
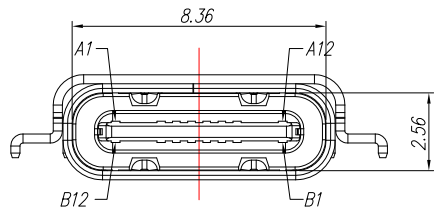

## SPECIFICATIONS

### Electrical:

1. Rating: 20V, 5.0 A
2. Dielectric Withstand Voltage: 100V AC
3. Contact Resistance: 30 mΩ Max
4. Insulation Resistance: 100 MΩ Min

### Mechanical:

1. Connector Mate and Unmate Force
  - 1.1 Mate force: 5~20 N
  - 1.2 Unmate force: 8~20 N

### Material:

1. Housing: PA46
2. Contact: C7025
3. Shell: SUS

### Finish:

1. Contact: Plated Gold in Mating Area ;  
Gold Plated on Solder Balls ;  
Nickel under plated overall
2. Shell: Nickel under Plated surface layer



TOLERANCE UNLESS OTHERWISE STATED :  
 Up to 5 ±0.2  
 Above 5 ~ 15 ±0.3  
 Above 15 ~ 30 ±0.4  
 Above 30 ~ 50 ±0.5  
 Angle ±0.3

3RD. ANGEL'S



UNITS MM

DRAWN BY:	DATE	MAT'L	TITLE	CONNECTOR
Jack Lu	07/05/23			
CHECKED BY:	DATE	FINISH	MODLE	USB TYPE C 2.0 沉板上H2.23mm CH0.35mm
Jacky Chen	07/05/23			
APPROVED BY:	DATE	SCALE	DWG NO.	SBC-160M25-20x-S165
Tony Kao	07/05/23	1 : 1	PART NO.	SBC-160M25-20x-S165
		SHEET NO.	1 of 1	
				SIZE A4
				VER R

ITEM NO.	DESCRIPTION	DRAWN	DATE