

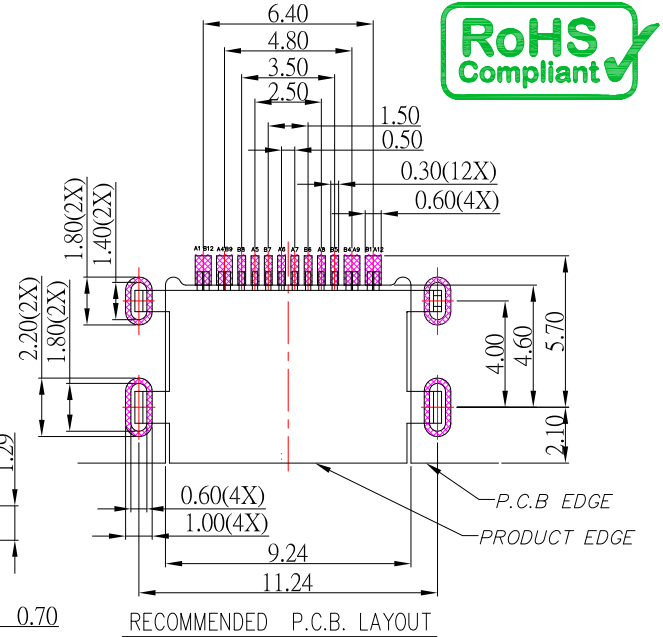

SBC-160M11x-20x-S331

DIM"A"	鍍層厚度:
Blank:0.85mm	Blank : 1u"
A : 0.55mm	2 : 15u"
	3 : 30u"

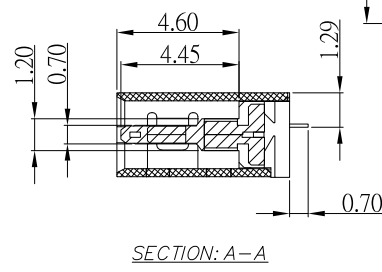
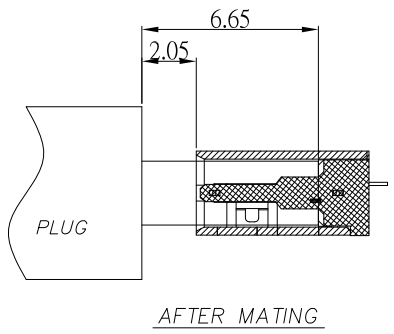
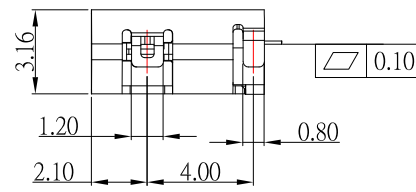
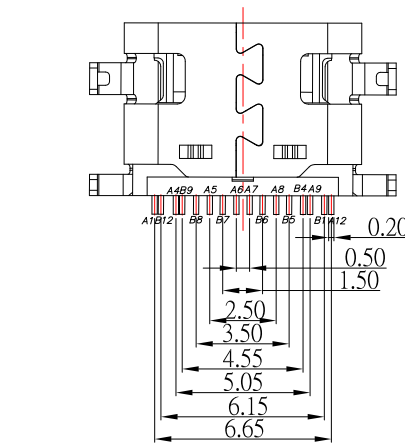
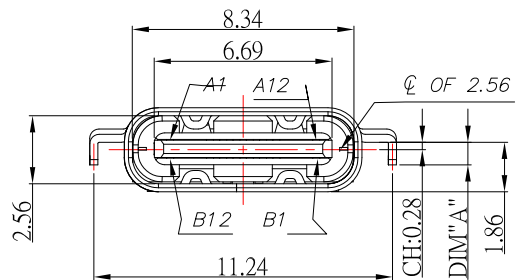
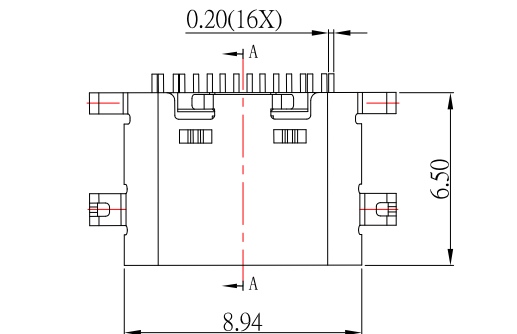

SPECIFICATIONS

- Electrical:**
- Rating: 5.0 V, 5.0 A
 - Dielectric Withstand Voltage: 100V AC
 - Contact Resistance: 40 mΩ Max
 - Insulation Resistance: 100 MΩ Min
- Mechanical:**
- Connector Mate and Unmate Force
 - Mate force: 5~20 N
 - Unmate force: 8~20 N
- Material:**
- Housing: LCP
 - Contact: C1814
 - Shell: SUS
- Finish:**
- Contact: Plated Gold in Mating Area ;
Tin Plated on Solder Balls ;
Nickel under plated overall
 - Shell: Nickel under Plated surface layer

USB TYPE-C PIN ASSIGNMENTS

PIN NUMBER	SIGNAL NAME	PIN NUMBER	SIGNAL NAME
A1	GND	B12	GND
A4	VBUS	B9	VBUS
A5	CC1	B8	SBU2
A6	Dp1	B7	Dn2
A7	Dn1	B6	Dp2
A8	SBU1	B5	CC2
A9	VBUS	B4	VBUS
A12	GND	B1	GND



TOLERANCE UNLESS OTHERWISE STATED:
 Up to 5 ±0.2
 Above 5 ~ 15 ±0.3
 Above 15 ~ 30 ±0.4
 Above 30 ~ 50 ±0.5
 Angle ±0.3°

3RD. ANGEL'S

UNITS MM

DRAWN BY:	DATE	MAT'L	TITLE	CONNECTOR
Jack Lu	03/16/23			
CHECKED BY:	DATE	FINISH	MODLE	USB TYPE C 2.0 沉板上H1.29mm
Jacky Chen	03/16/23			
APPROVED BY:	DATE	SCALE	DWG NO.	SBC-160M11x-20x-S331
Tony Kao	03/16/23	1 : 1	PART NO.	SBC-160M11x-20x-S331
		SHEET NO.	1 of 1	SIZE A4
				VER R2

ITEM NO.	DESCRIPTION	DRAWN	DATE
2	新增CH尺寸	Jack	031623
1	更新圖面	Jack	061622