

SBC-160S2H-20x-S331

鍍層厚度:

Blank	: 1u"
2	: 15u"
3	: 30u"

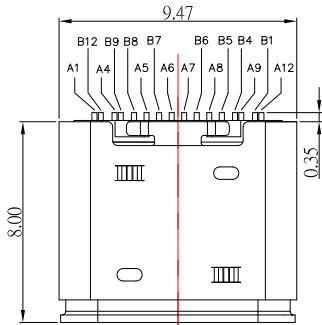

A1	GND	B12	GND
A4	VBUS	B9	VBUS
A5	CC1	B8	SBU2
A6	DP1	B7	DN2
A7	DN1	B6	DP2
A8	SBU1	B5	CC2
A9	VBUS	B4	VBUS
A12	GND	B1	GND
PIN	SIGNAL NAME	PIN	SIGNAL NAME

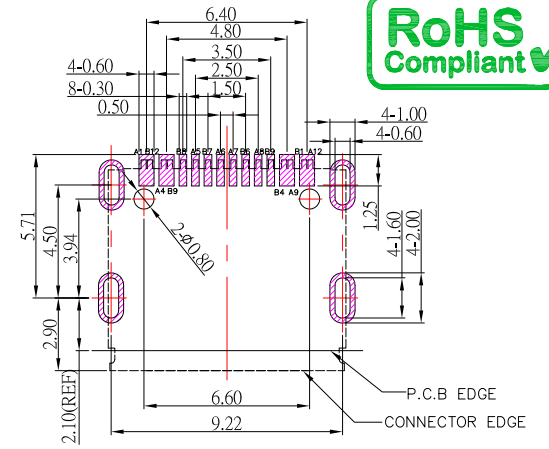

RECOMMENDED P.C.B. LAYOUT

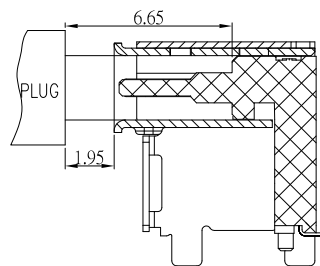
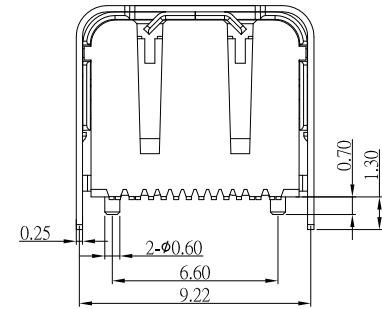
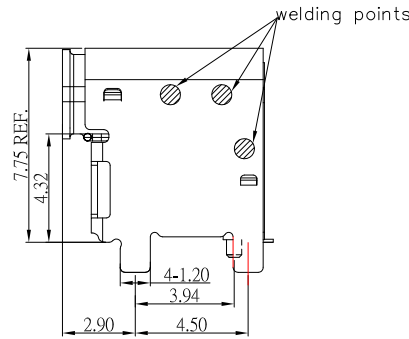
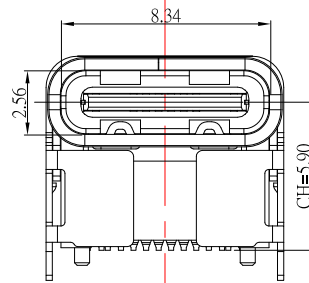
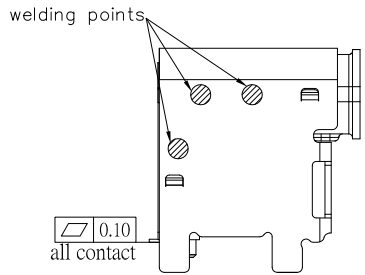

mating drawing

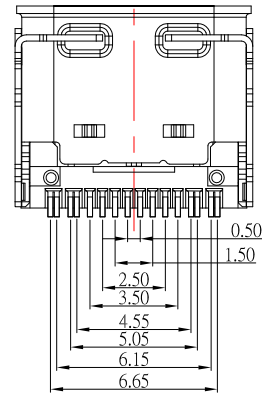

SPECIFICATIONS

Electrical:

1. Rating: 5.0 A
2. Voltage: 20V
3. Dielectric Withstand Voltage: 100V AC
4. Contact Resistance: 40 mΩ Max
5. Insulation Resistance: 100 MΩ Min

Mechanical:

1. Connector Mate and Unmate Force
 - 1.1 Mate force: 5~20 N
 - 1.2 Unmate force: 8~20 N

Material:

1. Housing: LCP
2. Contact: C18150
3. Shell: SUS

Finish:

1. Contact: Plated Gold in Mating Area ;
Gold Plated on Solder Balls ;
Nickel under plated overall
2. Shell: Nickel under Plated surface layer

6	更新樣式	Jack	061223
5	更新Voltage	Jack	051923
4	更新圖面	Jack	051823
3	更新材質	Jack	083121
2	更新料號	Jack	050621
1	更新圖面及料號	Jack	061920
ITEM NO.	DESCRIPTION	DRAWN	DATE



TOLERANCE UNLESS OTHERWISE STATED:
 Up to 5 ±0.2
 Above 5 ~ 15 ±0.3
 Above 15 ~ 30 ±0.4
 Above 30 ~ 50 ±0.5
 Angle ±0.3

3RD. ANGEL'S



UNITS MM

DRAWN BY:	DATE	MAT'L	TITLE	CONNECTOR
Jack Lu	06/12/23	FINISH	MODLE	USB 3.1 TYPE C 單排SMT墊高5.9 L 8.0mm 高導電銅
CHECKED BY:	DATE	SCALE	DWG NO.	SBC-160S2H-20x-S331
Jacky Chen	06/12/23	SHEET NO.	PART NO.	SBC-160S2H-20x-S331
APPROVED BY:	DATE	1 of 1		SIZE A4
Tony Kao	06/12/23			VER R6