

PUSH OFF	10.1
PUSH ON	8.9

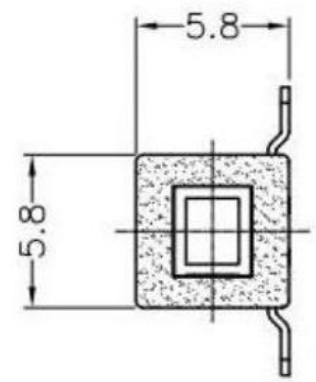

PUSH OFF PUSH ON

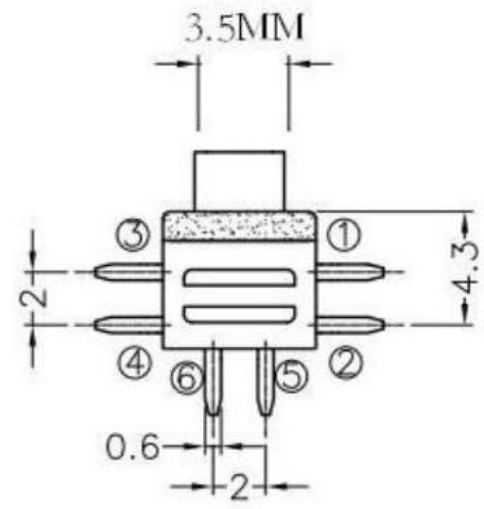
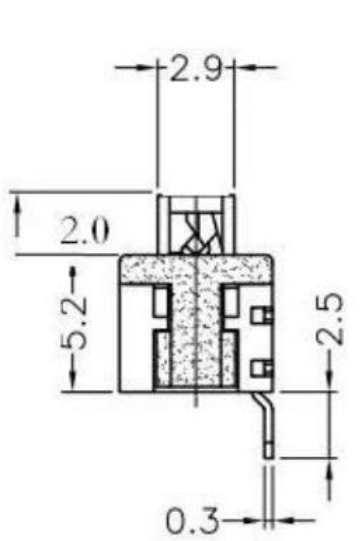
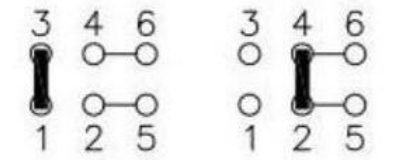

SCHEMATIC (NON-SHORTING)

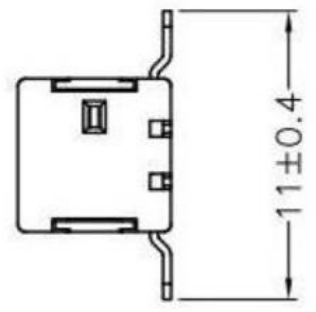
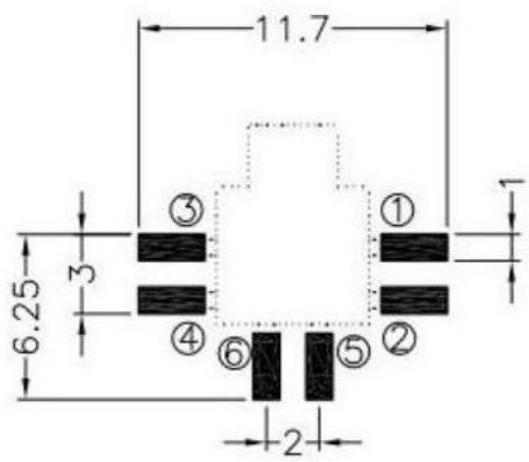

SPECIFICATIONS

- (1) LIFE TEST: 10000 cycles at a speed of 15-18 cycles
- (2) CONTACT RESISTANCE: 100mΩ max
- (3) INSULATION RESISTANCE: 100MΩ min
- (4) DIELECTRIC STRENGTH: 250V AC FOR 1MIN
- (5) OPERATING TEMPERATURE: -16°C - +60°C
- (6) RATING: 0.1A 30V DC
- (7) FUNCTION: 2P2T
- (8) TIMING: NON-SHORTING
- (9) OPERATING FORCE: 180gf ± 50gf

8										
7										
6										
5	SPRING	SUS304	1	NATURAL						
4	CAM STICK	SUS304	1	NATURAL						
3	CASE	PA66/BRASS STRIP	1	GREY/Ag PLATED						
2	COVER	PA66+15%F.G	1	BLACK						
1	NOB	PA66+15%F.G/PBS STRIP	1	BLACK/Ag CLAD						
NO.	PARTS	MATERIALS	Q'TY							
					TOLERANCE UNLESS SPECIFIED					
					WITHIN 1.5mm : ±0.1mm	A	2016-10-14	初版		
					OVER 1.5mm : ±0.2mm	ISSUE	DATE	DESCRIPTIONS OF REVISION		APPD.
					TITLE : VERTICAL PUSH SWITCH		UNIT : mm	DRWG NO.:		
					MODEL:		SCALE: 5:1	DWN.		2016-10-14
					東莞市高迪電子有限公司 DONGGUANGAODI ELECTRONICS CO.,LTD.			CHK'D		2016-10-14
								APPD.		