

RELEASE	5.0
LOCK	3.6

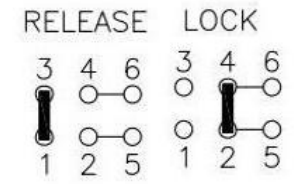
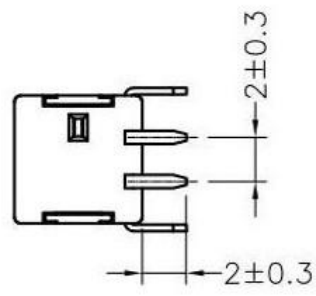
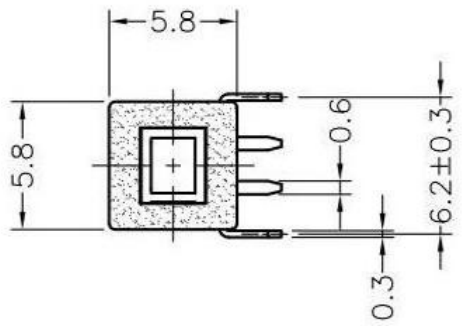
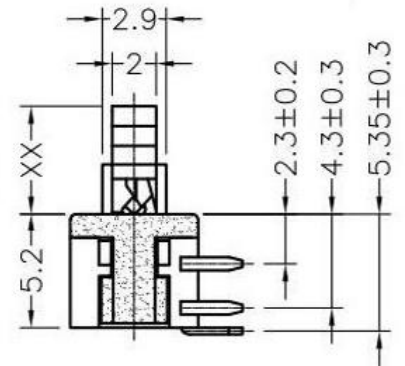

SCHEMATIC (NON-SHORTING)

SPECIFICATIONS

- (1) LIFE TEST: 10000 cycles at a speed of 15-18 cycles
- (2) CONTACT RESISTANCE: 100mΩ max
- (3) INSULATION RESISTANCE: 100MΩ min
- (4) DIELECTRIC STRENGTH: 250V AC FOR 1MIN
- (5) OPERATING TEMPERATURE: -16°C - +60°C
- (6) RATING: 0.1A 30V DC
- (7) FUNCTION: 2P2T
- (8) TIMING: NON-SHORTING
- (9) OPERATING FORCE: 180gf ± 50gf

8										
7										
6										
5	SPRING	SUS304	1	NATURAL						
4	CAM STICK	SUS304	1	NATURAL						
3	CASE	PA66/BRASS STRIP	1	GREY/Ag PLATED						
2	COVER	PA66+15%F.G	1	BLACK						
1	KNOB	PA66+15%F.G/PBS STRIP	1	BLACK/Ag CLAD						
NO.	PARTS	MATERIALS	Q'TY							
					TOLERANCE UNLESS SPECIFIED					
					WITHIN 1.5mm : ±0.1mm		A	2016-10-14	初版	
					OVER 1.5mm : ±0.2mm		ISSUE	DATE	DESCRIPTIONS OF REVISION	
					TITLE : VERTICAL PUSH SWITCH			UNIT : mm	DRWG NO.:	
					MODEL:			SCALE: 5:1	DWN.	2016-10-14
					东莞市高迪电子有限公司 DONGGUANGAODI ELECTRONICS CO.,LTD.			CHK'D		2016-10-14
								APPD.		