

view A
scale 1:1

FREE	12.4
LOCK	11.5

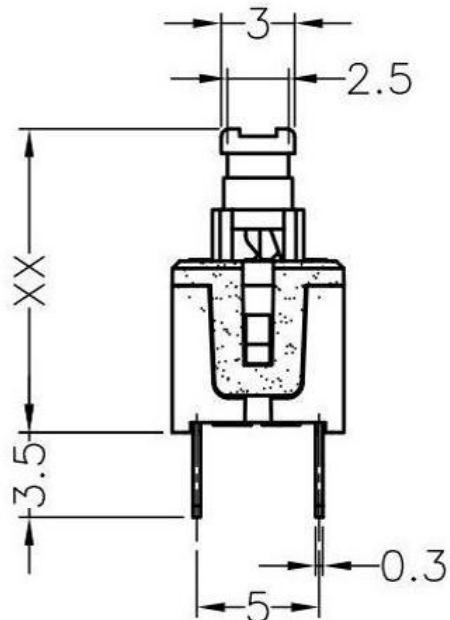

View A

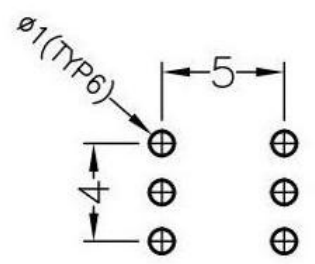
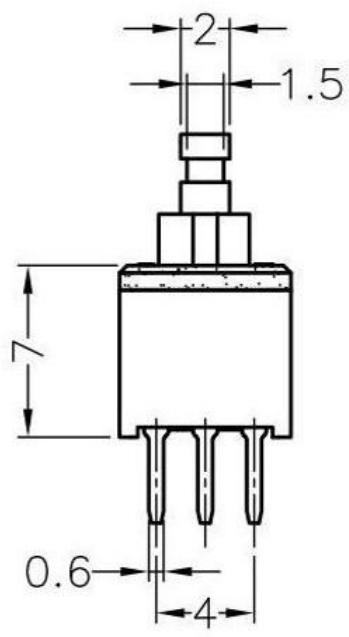
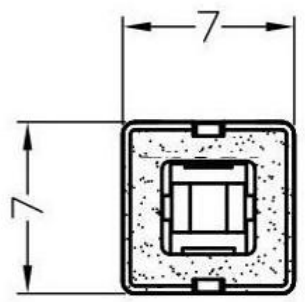
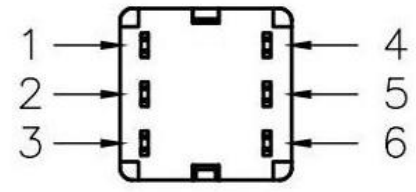

PCB LAYOUT

FREE			LOCK		
1	2	3	1	2	3
○	○	○	○	○	○
○	○	○	○	○	○
4	5	6	4	5	6

SPECIFICATIONS

- (1) LIFE TEST: 10000 cycles at a speed of 15-18 cycles
- (2) CONTACT RESISTANCE: 100mΩmax
- (3) INSULATION RESISTANCE: 100MΩmin
- (4) DIELECTRIC STRENGTH: 250V AC FOR 1MIN
- (5) OPERATING TEMPERATURE: -16°C - +60°C
- (6) RATING: 0.1A 30V DC
- (7) FUNCTION: 2P2T
- (8) TIMING: NON-SHORTING
- (9) OPERATING FORCE: 180gf ± 50gf

NO.	PARTS	MATERIALS	Q'TY	TOLERANCE UNLESS SPECIFIED	ISSUE	DATE	DESCRIPTIONS OF REVISION	APPD.	
8									
7									
6				WITHIN 1.5mm : ±0.1mm	A	2016-10-14	初版		
5	SPRING	SUS304	1	OVER 1.5mm : ±0.2mm	ISSUE	DATE	DESCRIPTIONS OF REVISION	APPD.	
4	CAM STICK	SUS304	1		TITLE : VERTICAL PUSH SWITCH		UNIT : mm	DRWG NO.:	
3	CASE	PA66/BRASS STRIP	1		MODEL:		SCALE: 5:1	DWN.	
2	COVER	PA66+15%F.G	1					2016-10-14	
1	KNOB	PA66+15%F.G/PBS STRIP	1					2016-10-14	
				東莞市高迪電子有限公司 DONGGUANGAODIELECTRONICS CO.,LTD.				CHK'D	2016-10-14
								APPD.	