

CAD FILE:

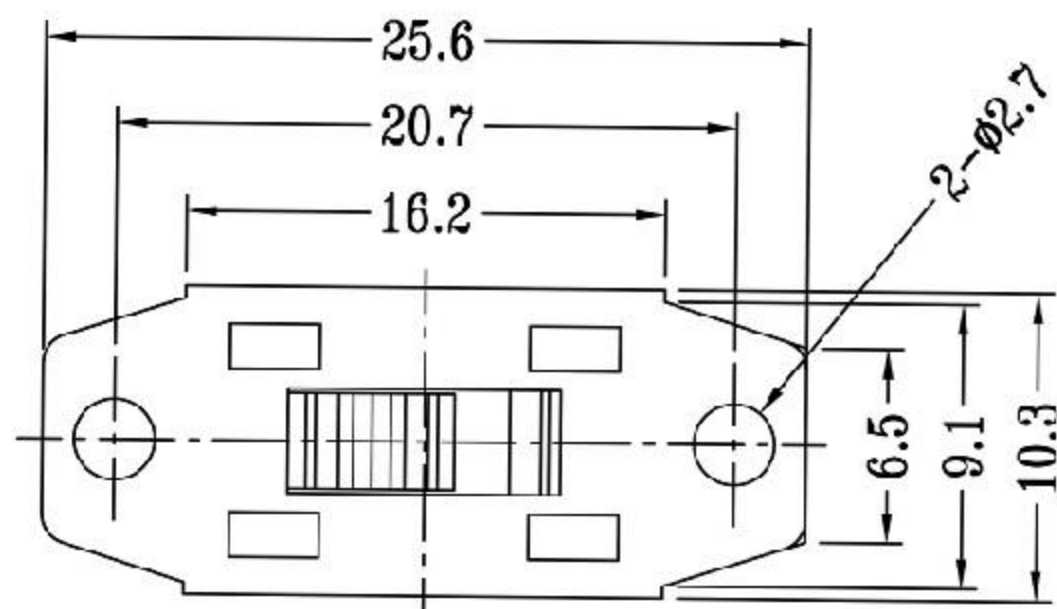
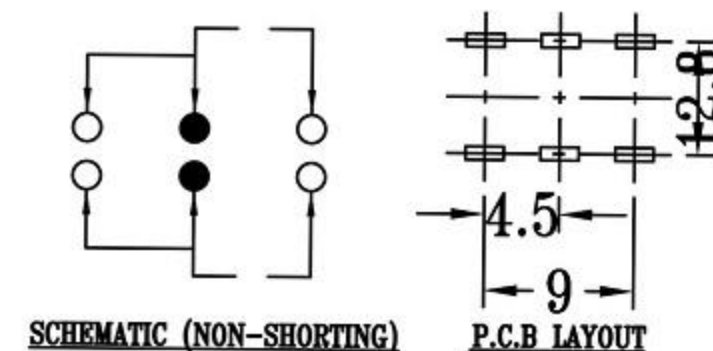
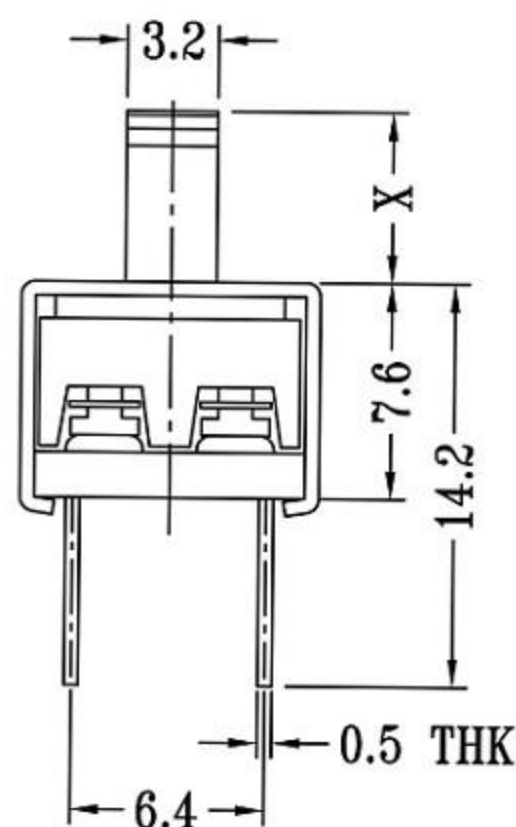
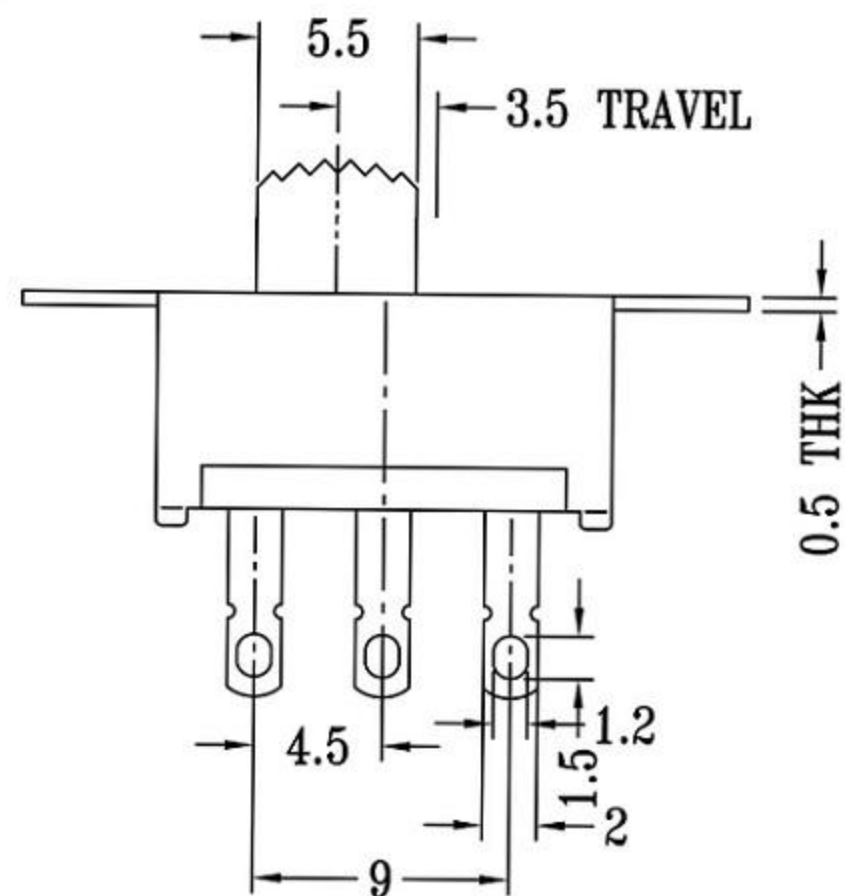

注: "*"表示关键尺寸(6个)

大电流拨动开关技术参数:

1. 额定负荷: AC 125V 250V 3A 6A 10A
2. 接触阻抗: $\leq 50m\Omega$
3. 绝缘阻抗: $\geq 100m\Omega$ DC500V
4. 耐焊温度: $250 \pm 5^\circ$ 5s
5. 使用寿命: 10,000 cycles
6. 使用温度: -25°C to 80°C
7. 使用湿度: $\leq 85\% \text{ RH}$
8. 操作力: 160gf 256gf 300gf 可定制
9. 手柄长度: 2mm-10mm 可定制

NO.	PARTS	MATERIALS	Q'TY	FINISH	TOLERANCE UNLESS SPECIFIED	ISSUE	DATE	DESCRIPTIONS OF REVISION	APPD.
8									
7	STEEL BALL	STEEL	1	NATURAL					
6	SPRING	STEEL WIRE	1	NATURAL					
5	CONTACT CLIP	PBS STRIP	2	Ag PLATED					
4	TERMINAL	BRASS STRIP	8	Ag PLATED					
3	BASE	PHENOLIC RESIN	1	NATURAL					
2	FRAME	STEEL STRIP	1	Ni PLATED					
1	KNOB	POM	1	BLACK					
					TITLE : VERTICAL SLIDE SWITCH		UNIT : mm	DRWG NO.:	
					MODEL:		SCALE: 3:1	DWN.	2012-10-26
					东莞市高迪电子有限公司			CHK'D	
								APPD.	2012-10-26