

X(mm)
2mm
3mm
4mm
5mm
6mm
7mm
8mm
9mm

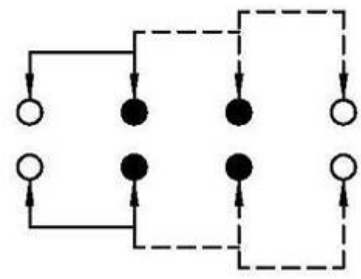

SCHEMATIC (NON-SHORTING)

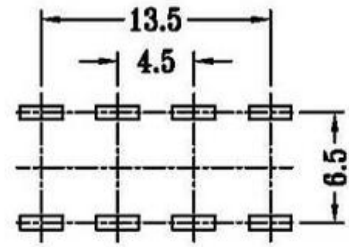
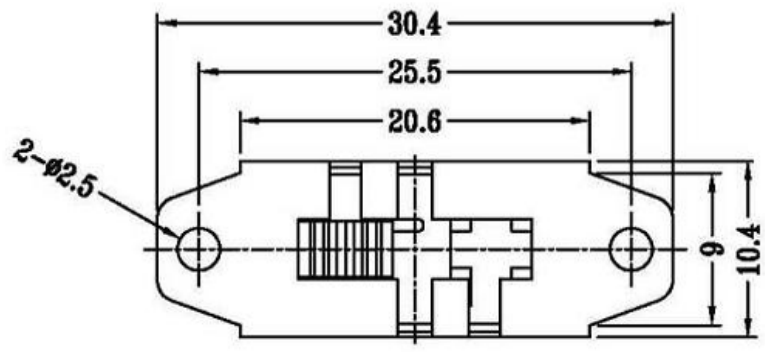

**P.C.B LAYOUT
BOTTOM VIEW**

- 1.RATING 额定值: 3A 250V AC
- 2.CONTACT RESISTANCE 接触电阻: 100mΩ以下
3. INSULATION RESISTANCE 绝缘电阻: 100MΩ以上 500DC/1min
- 4.DIELECTRIC STRENGTH 耐电压: 500V AC/1min
5. OPERATING FORCE 操作力度: 350±100gf
- 6.LIFE TEST 寿命测试: 10000cycles
- 7.SOLDERABILITY TEST 可焊性测试: 焊接面积可达95%以上
- 8.SOLDERING HEAT TEST 耐焊性测试:
过炉焊260°C 浸锡255±5°C 3±1 S 手焊 380±10°C 3±1 S
- 9.COLD TEST耐冷: -25±3°C 48H
- 10.HEAT TEST耐热: 70±2°C 48H
- 11.HUMIDITY 潮湿: 环境温度40±2°C 湿度90~95% 96H

NO.	DESCRIPTION	QTY	MATERIAL	REMARK
7	STEEL BALL	1	STAINLESS	Natural
6	SPRING	1	STAINLESS	Natural
5	CONTACT CLIP	1	PHOSPHOR BRONZE	Ag-plated
4	TERMINAL	4	BRASS	Ag-plated
3	BASE	1	PHENOLIC RESIN	Natural
2	FRAME	1	SPCC	Ni-Plated
1	KNOB	1	POM	Black

ITEM NO.	DESCRIPTION	DRAWN	DATE
3	新增SPEC	Jack	11/2014
2	更新材質	Jack	04/2014
1	更新尺寸6.0改5.8	Jack	03/17/14

东莞市高迪电子有限公司
 Dong Guan KDRR Electronic Switch Jack Co., Ltd.

TOLERANCE UNLESS OTHERWISE STATED:	Up to 5 ±0.2	Above 5 ~ 15 ±0.3	Above 15 ~ 30 ±0.4	Above 30 ~ 50 ±0.5	Angle ±0.3	3RD. ANGEL'S		UNITS	MM
------------------------------------	--------------	-------------------	--------------------	--------------------	------------	--------------	--	-------	----

DRAWN BY:	DATE	MAT'L	TITLE	SWITCH
Jack Lu	11/20/14			
CHECKED BY:	DATE	FINISH	MODLE	SLIDE SWITCH
Jacky Chen	11/20/14			
APPROVED BY:	DATE	SCALE	DWG NO.	SIZE
Tony Kao	11/20/14	1:1		A4
		SHEET NO.	PART NO.	VER
		1 of 1		R3