

X(mm)
2mm
3mm
4mm
5mm
6mm
7mm
8mm
9mm

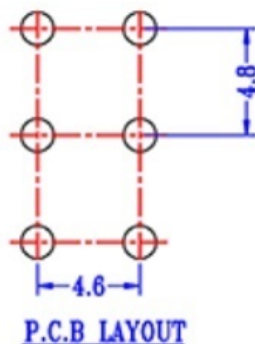

1. RATING 额定值: 1.5A 3A 125V AC
2. CONTACT RESISTANCE 接触电阻: 30mΩ 以下
3. INSULATION RESISTANCE 绝缘电阻: 100MΩ 以上 500DC/1min
4. DIELECTRIC STRENGTH 耐电压: 500V AC/1min
5. OPERATING FORCE 操作力度: 250±100gf
6. LIFE TEST 寿命测试: 10000cycles
7. SOLDERABILITY TEST 可焊性测试: 焊接面积可达 95% 以上
8. SOLDERING HEAT TEST 耐焊性测试: 浸锡 255±5°C 3±1 S 手焊 380±10°C 3±1 S
9. COLD TEST 耐冷: -25±3°C 48H
10. HEAT TEST 耐热: 70±2°C 48H
11. HUMIDITY 潮湿: 环境温度 40±2°C 湿度 90~95% 96H

NO.	DESCRIPTION	QTY	MATERIAL	REMARK
7	STEEL BALL	1	STAINLESS	Natural
6	SPRING	1	STAINLESS	Natural
5	CONTACT CLIP	1	PHOSPHOR BRONZE	Ag-plated
4	TERMINAL	4	BRASS	Ag-plated
3	BASE	1	PHENOLIC RESIN	Natural
2	FRAME	1	SPCC	Ni-Plated
1	KNOB	1	POM	Black

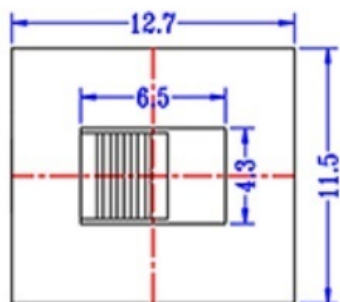

**东莞市高迪电子有限公司**  
Dong Guan KDRR Electronic Switch Jack Co., Ltd.

TOLERANCE UNLESS OTHERWISE STATED:   
 Up to 5 ±0.2  
 Above 5 ~ 15 ±0.3  
 Above 15 ~ 30 ±0.4  
 Above 30 ~ 50 ±0.5  
 Angle ±0.3

3RD. ANGEL'S



UNITS MM

DRAWN BY: Jack Lu	DATE: 11/20/14	MAT'L	TITLE: SWITCH
CHECKED BY: Jacky Chen	DATE: 11/20/14	FINISH	MODLE: SLIDE SWITCH
APPROVED BY: Tony Kao	DATE: 11/20/14	SCALE: 1:1	DWG NO.
		SHEET NO: 1 of 1	PART NO.

ITEM NO.	DESCRIPTION	DRAWN	DATE
3	新增SPEC	Jack	11/20/14
2	更新材質	Jack	04/02/14
1	更新尺寸6.0改5.8	Jack	03/17/14