

| X(mm) |
|-------|
| 2mm |
| 3mm |
| 4mm |
| 5mm |
| 6mm |
| 7mm |
| 8mm |
| 9mm |

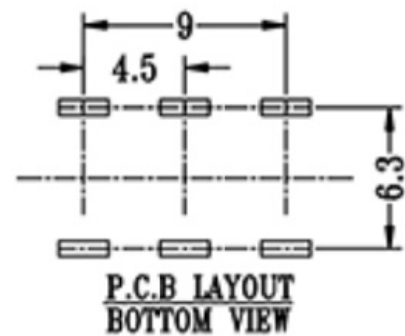
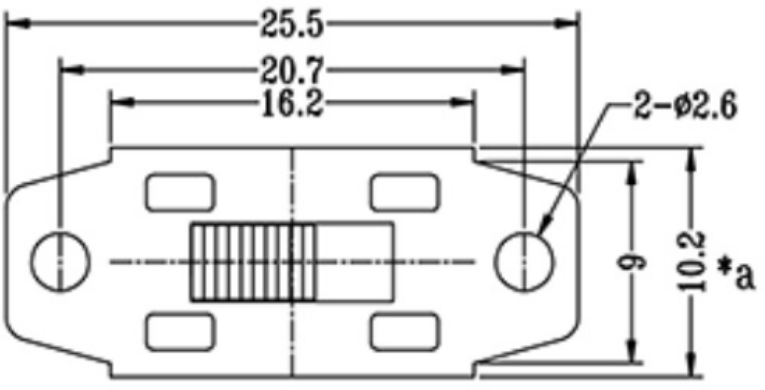
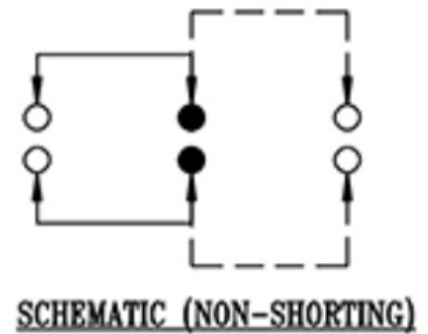

- 1.RATING 额定值: 1.5A 3A 125V AC
- 2.CONTACT RESISTANCE 接触电阻: 30mΩ 以下
3. INSULATION RESISTANCE 绝缘电阻 :100MΩ 以上 500DC/1min
- 4.DIELECTRIC STRENGTH 耐电压: 500V AC/1min
5. OPERATING FORCE 操作力度:250±100gf
- 6.LIFE TEST 寿命测试: 10000cycles
- 7.SOLDERABILITY TEST 可焊性测试: 焊接面积可达 95%以上
- 8.SOLDERING HEAT TEST 耐焊性测试: 浸锡 255±5°C 3±1 S 手焊 380±10°C 3±1 S
- 9.COLD TEST 耐冷: -25±3°C 48H
- 10.HEAT TEST 耐热: 70±2°C 48H
- 11.HUMIDITY 潮湿: 环境温度 40±2°C 湿度 90~95% 96H

| NO. | DESCRIPTION | QTY | MATERIAL | REMARK |
|-----|--------------|-----|-----------------|-----------|
| 7 | STEEL BALL | 1 | STAINLESS | Natural |
| 6 | SPRING | 1 | STAINLESS | Natural |
| 5 | CONTACT CLIP | 1 | PHOSPHOR BRONZE | Ag-plated |
| 4 | TERMINAL | 4 | BRASS | Ag-plated |
| 3 | BASE | 1 | PHENOLIC RESIN | Natural |
| 2 | FRAME | 1 | SPCC | Ni-Plated |
| 1 | KNOB | 1 | POM | Black |

| ITEM NO. | DESCRIPTION | DRAWN | DATE |
|----------|-------------|-------|----------|
| 3 | 新增SPEC | Jack | 11/2014 |
| 2 | 更新材質 | Jack | 04/2014 |
| 1 | 更新尺寸6.0改5.8 | Jack | 03/17/14 |

东莞市高迪电子有限公司
DongGuan KDRR Electronic Switch Jack Co., Ltd.

TOLERANCE UNLESS OTHERWISE STATED:
 Up to 5 ±0.2
 Above 5 ~ 15 ±0.3
 Above 15 ~ 30 ±0.4
 Above 30 ~ 50 ±0.5
 Angle ±0.3

3RD. ANGEL'S

UNITS MM

| DRAWN BY: | DATE | MAT'L | TITLE | SWITCH |
|--------------|----------|-----------|----------|--------------|
| Jack Lu | 11/20/14 | | | |
| CHECKED BY: | DATE | FINISH | MODLE | SLIDE SWITCH |
| Jacky Chen | 11/20/14 | | | |
| APPROVED BY: | DATE | SCALE | DWG NO. | SIZE |
| Tony Kao | 11/20/14 | 1:1 | | A4 |
| | | SHEET NO. | PART NO. | VER |
| | | 1 of 1 | | R3 |