

SCHEMATIC (NON-SHORTING)

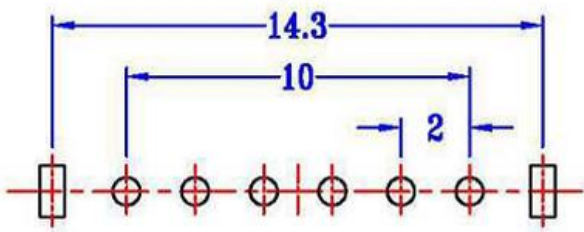
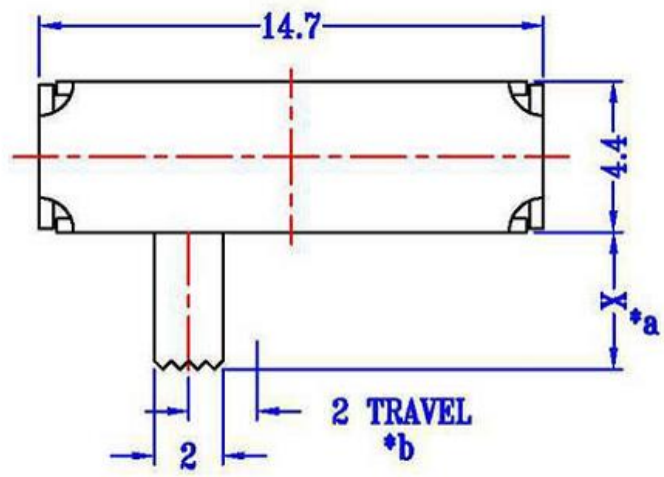

P.C.B LAYOUT  
BOTTOM VIEW

X(mm)
2mm
3mm
4mm
5mm
6mm
7mm
8mm
9mm

SPECIFICATIONS

Rating	DC 50V 0.5A
Circuit	
Contact Resistance	200mΩ Max.
Insulation Resistance	100MΩ Min.
Operating Force	250gf ±100gf
Operating Life (cycles)	10,000

NO.	DESCRIPTION	QTY	MATERIAL	REMARK
7	STEEL BALL	1	STAINLESS	Natural
6	SPRING	1	STAINLESS	Natural
5	CONTACT CLIP	1	PHOSPHOR BRONZE	Ag-plated
4	TERMINAL	4	BRASS	Ag-plated
3	BASE	1	PHENOLIC RESIN	Natural
2	FRAME	1	SPCC	Ni-Plated
1	KNOB	1	POM	Black

ITEM NO.	DESCRIPTION	DRAWN	DATE
3	新增SPEC	Jack	11/2014
2	更新材質	Jack	04/2014
1	更新尺寸6.0改5.8	Jack	03/17/14

**东莞市高迪电子有限公司**  
 Dong Guan KDRR Electronic Switch Jack Co., Ltd.

TOLERANCE UNLESS OTHERWISE STATED:
 

Up to 5	±0.2
Above 5 ~ 15	±0.3
Above 15 ~ 30	±0.4
Above 30 ~ 50	±0.5
Angle	±0.3°

 3RD. ANGEL'S UNITS MM

DRAWN BY:	DATE	MAT'L	TITLE	SWITCH
Jack Lu	11/20/14			
CHECKED BY:	DATE	FINISH	MODLE	SLIDE SWITCH
Jacky Chen	11/20/14			
APPROVED BY:	DATE	SCALE	DWG NO.	SIZE
Tony Kao	11/20/14	1:1		A4
		SHEET NO.	PART NO.	VER
		1 of 1		R3