

SCHEMATIC (NON-SHORTING)

X(mm)
2mm
3mm
4mm
5mm
6mm
7mm
8mm
9mm

SPECIFICATIONS

Rating	DC 50V 0.5A
Circuit	
Contact Resistance	200mΩ Max.
Insulation Resistance	100MΩ Min.
Operating Force	250gf ±100gf
Operating Life (cycles)	10,000

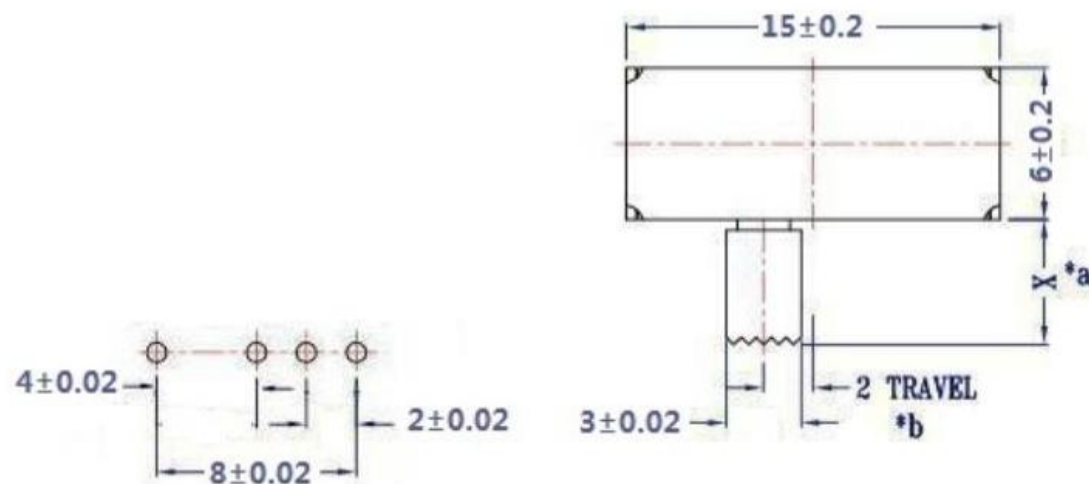

P.C.B LAYOUT
BOTTOM VIEW

7	STEEL BALL	1	STAINLESS	Natural
6	SPRING	1	STAINLESS	Natural
5	CONTACT CLIP	1	PHOSPHOR BRONZE	Ag-plated
4	TERMINAL	4	BRASS	Ag-plated
3	BASE	1	PHENOLIC RESIN	Natural
2	FRAME	1	SPCC	Ni-Plated
1	KNOB	1	POM	Black
NO.	DESCRIPTION	QTY	MATERIAL	REMARK



东莞市高迪电子有限公司
DongGuan KDRR Electronic Switch Jack Co., Ltd.

TOLERANCE UNLESS OTHERWISE STATED:
 Up to 5 ±0.2
 Above 5 ~ 15 ±0.3
 Above 15 ~ 30 ±0.4
 Above 30 ~ 50 ±0.5
 Angle ±0.3

3RD. ANGEL'S



UNITS MM

DRAWN BY:	DATE	MAT'L	TITLE	SWITCH
Jack Lu	11/20/14	FINISH	MODLE	SLIDE SWITCH
CHECKED BY:	DATE	SCALE	DWG NO.	SIZE
Jacky Chen	11/20/14	1:1		A4
APPROVED BY:	DATE	SHEET NO.	PART NO.	VER
Tony Kao	11/20/14	1 of 1		R3

3	新增SPEC	Jack	11/20/14
2	更新材質	Jack	04/02/14
1	更新尺寸6.0改5.8	Jack	03/17/14
ITEM NO.	DESCRIPTION	DRAWN	DATE