

CAD FILE:

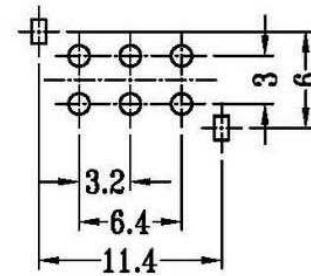
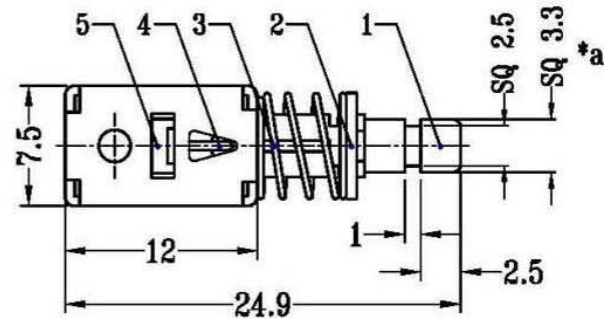
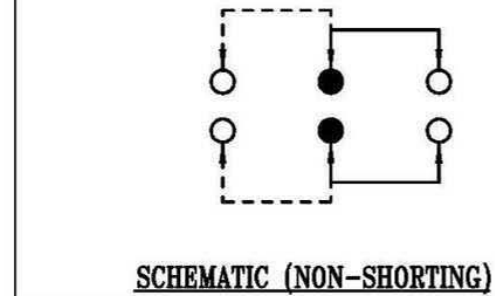
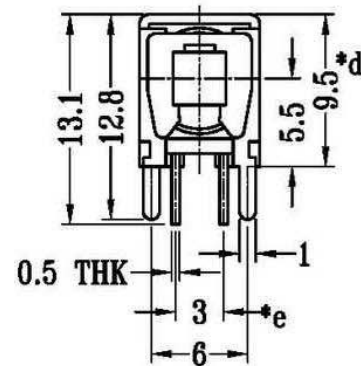
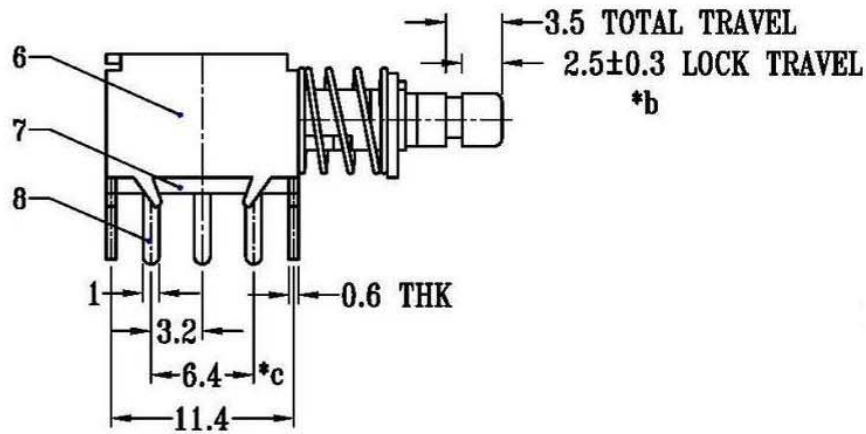

P.C.B LAYOUT  
BOTTOM VIEW

注: "\*"表示关键尺寸(5个)

9	CONTACT CLIP	PBS C5210R-EH	2	Ag CLAD
8	TERMINAL	BRASS STRIP	6	Ag PLATED OVER Ni PLATED
7	BASE	PHENOLIC RESIN	1	NATURAL
6	FRAME	STEEL STRIP	1	Ni PLATED
5	SPRING PLATE	PBS STRIP	1	NATURAL
4	CAM STICK	PBS WIRE	1	NATURAL
3	SPRING	STEEL WIRE	1	Ni PLATED
2	BLOCK	STEEL STRIP	1	Ni PLATED
1	KNOB	PA66	1	BLACK
NO.	PARTS	MATERIALS	Q'TY	FINISH

TOLERANCE UNLESS SPECIFIED					
WITHIN 1.5mm	: ±0.1mm	A	2008.6.8	初版	张小姐
OVER 1.5mm	: ±0.2mm	ISSUE	DATE	DESCRIPTIONS OF REVISION	APPD.
TITLE : PUSH SWITCH			UNIT : mm	DRWG NO.:	
MODEL:			SCALE: 2:1	DWN. 张小姐	2008.6.8
东莞市高迪电子有限公司 KDRR Electronic Switch JacK Co., Ltd.				CHK'D 刘工	2008.6.8
				APPD.	