

CAD FILE:

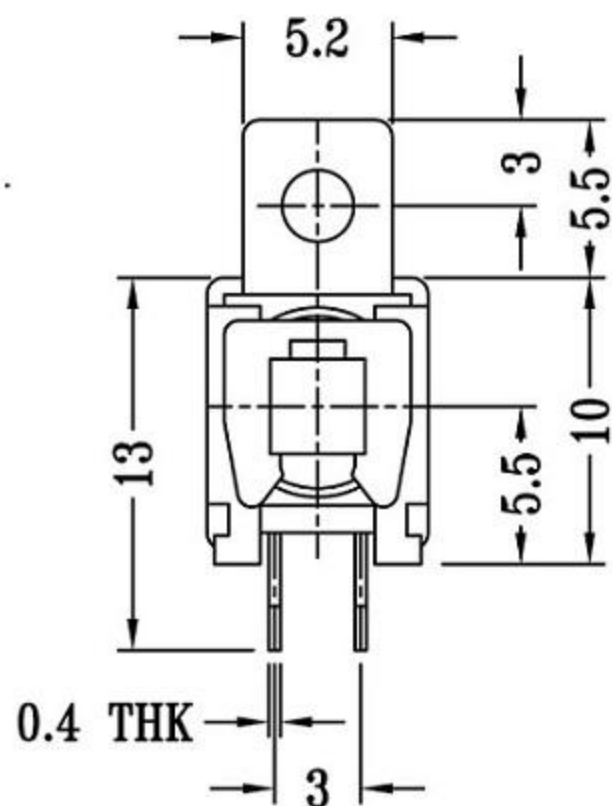
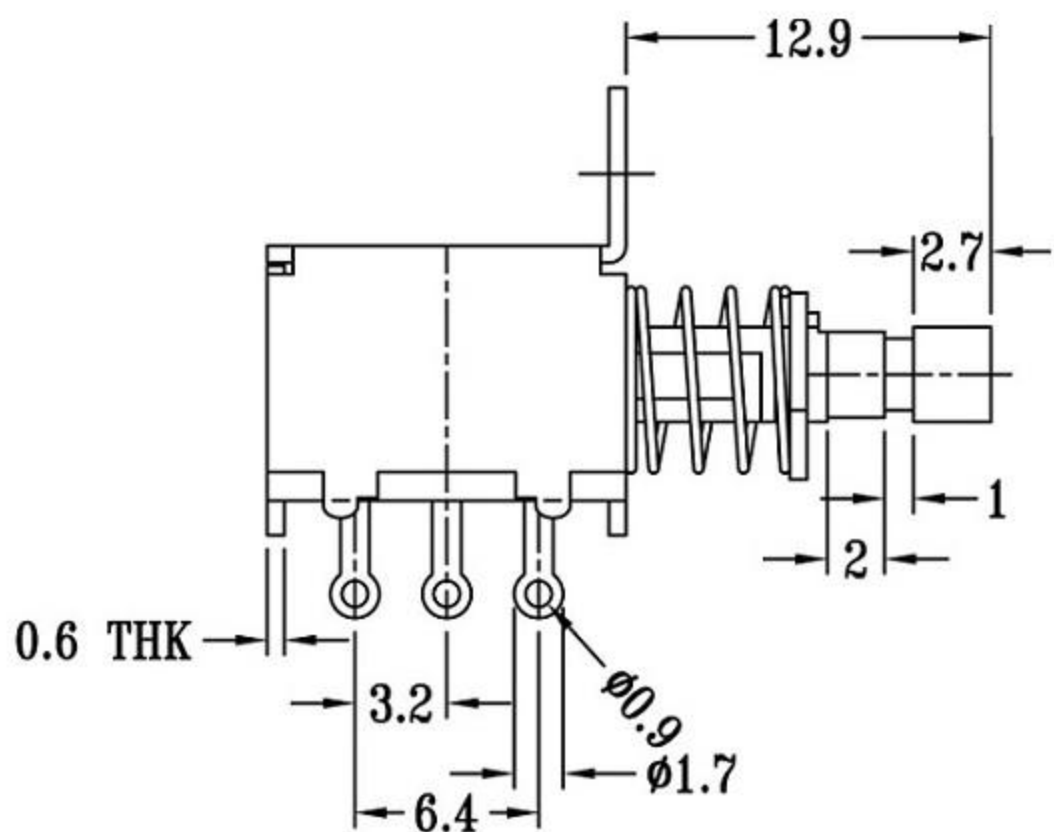
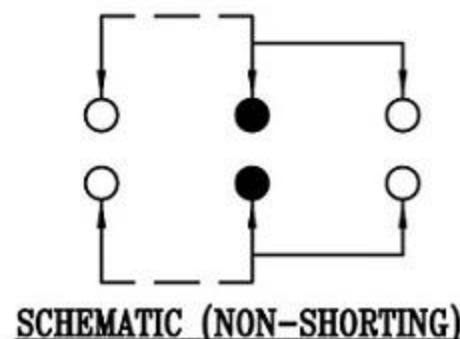
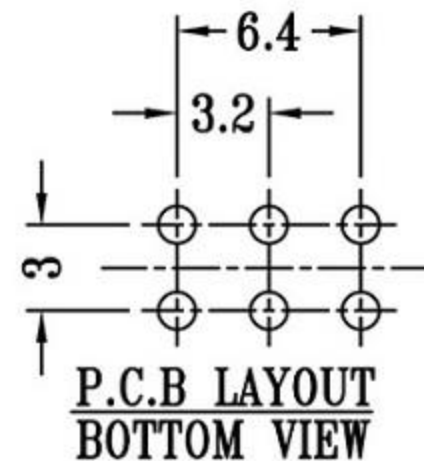
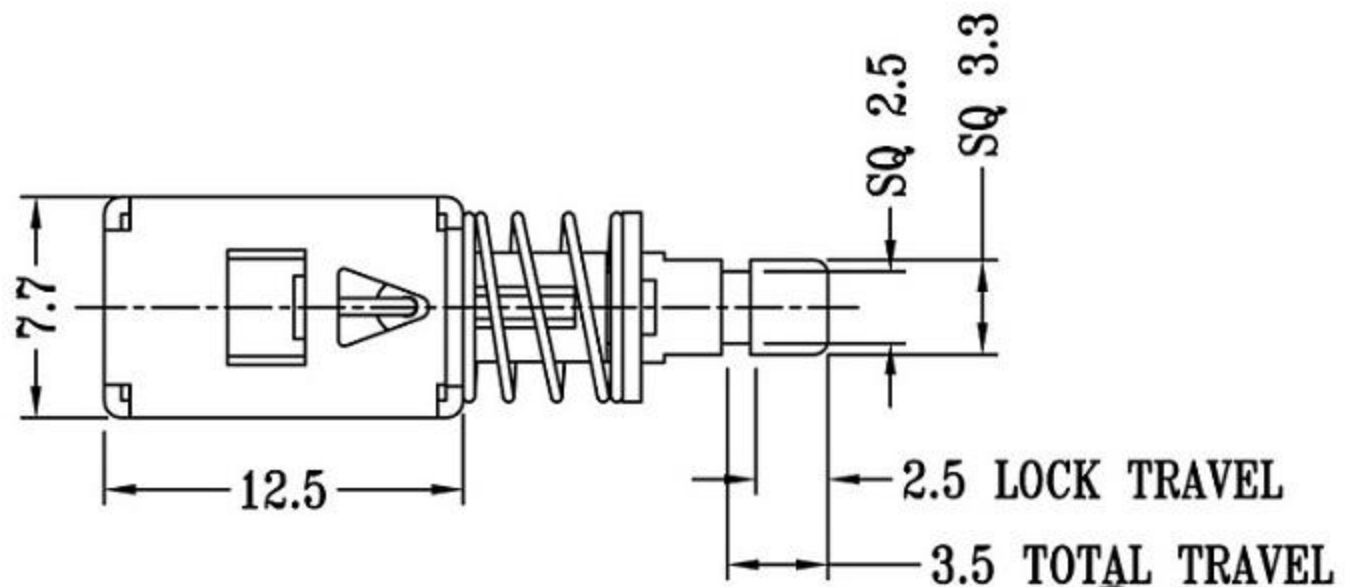

按键开关技术参数:

1. 额定负荷: DC 30V 50V 0.1A 0.5A
2. 接触阻抗:  $\leq 50m\Omega$
3. 绝缘阻抗: DC 250V  $\geq 100m\Omega$
4. 耐焊温度:  $250 \pm 5^\circ$  5s
5. 使用寿命: 100,000 cycles
6. 使用温度:  $-25^\circ\text{C}$  to  $80^\circ\text{C}$
7. 使用湿度:  $\leq 85\%$  RH
8. 操作力:  $240gf \pm 80gf$
9. 功能选择: 自锁/无锁
10. 按压力可定制

NO.	PARTS	MATERIALS	Q'TY	FINISH	TOLERANCE UNLESS SPECIFIED		TITLE : PUSH SWITCH		UNIT : mm	DRWG NO.:		
8					WITHIN 1.5mm	$\pm 0.1mm$	A	2012-11-06		初版		
7					OVER 1.5mm	$\pm 0.2mm$	ISSUE	DATE		DESCRIPTIONS OF REVISION		
6	SPRING	STEEL WIRE	1	NATURAL								
5	CONTACT CLIP	PBS C5210R-EH	2	Ag CLAD								
4	BASE	PHENOLIC RESIN	1	NATURAL								
3	TERMINAL	BRASS STRIP	6	Ag PLATED OVER Ni PLATED								
2	FRAME	Electrolytic strip	1	NATURAL								
1	KNOB	PC	1	BLACK								
					MODEL:				SCALE: 2:1			
										DWN.		2012-11-06
										CHK'D		2012-11-06
										APPD.		2012-11-06