

CAD FILE:

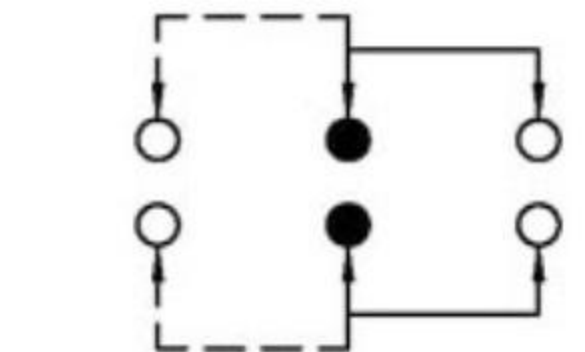

SCHEMATIC (NON-SHORTING)

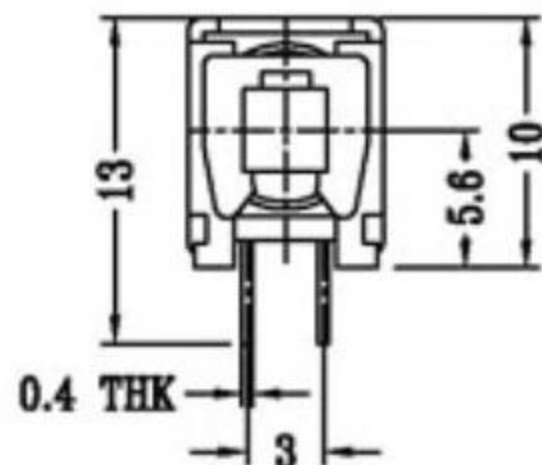
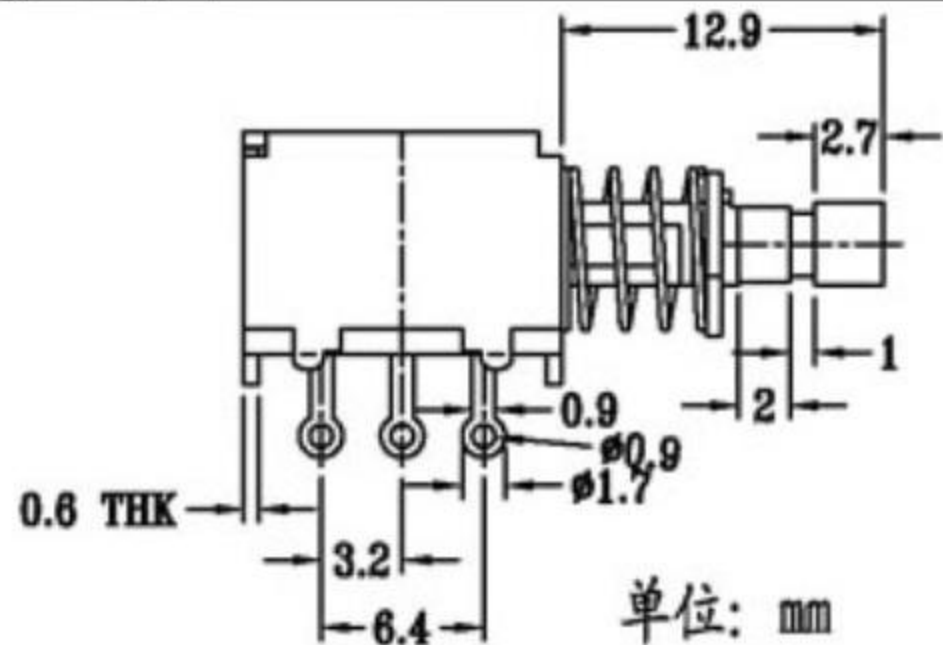
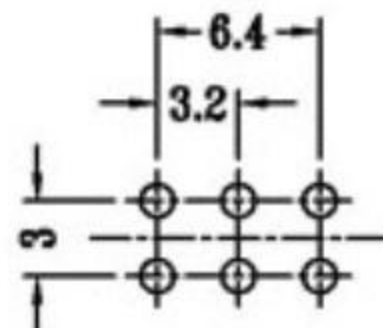
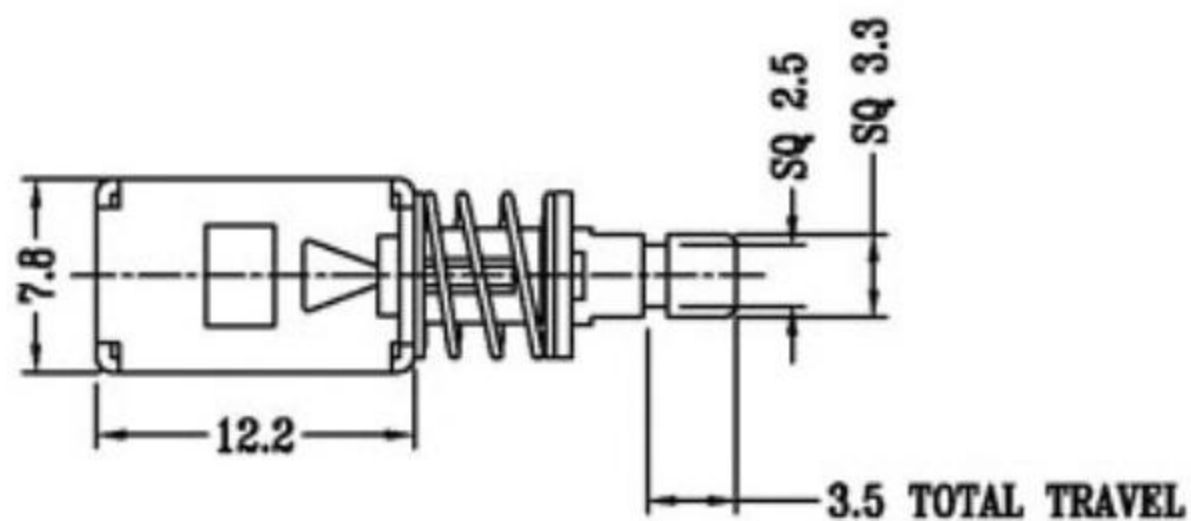

P.C.B LAYOUT
BOTTOM VIEW

按键开关技术参数:

1. 额定负荷: DC 30V 50V 0.1A 0.5A
2. 接触阻抗: $\leq 50m\Omega$
3. 绝缘阻抗: DC 250V $\geq 100m\Omega$
4. 耐焊温度: $250 \pm 5^\circ$ 5s
5. 使用寿命: 100,000 cycles
6. 使用温度: -25°C to 80°C
7. 使用湿度: $\leq 85\%$ RH
8. 操作力: $240gf \pm 80gf$
9. 功能选择: 自锁/无锁
10. 按压力可定制

注: "*" 表示关键尺寸(6个).

| NO. | PARTS | MATERIALS | Q'TY | FINISH | TOLERANCE UNLESS SPECIFIED | | | DESCRIPTIONS OF REVISION | | |
|-----|--------------|--------------------|------|--------------------------|-------------------------------|-------|------------|--------------------------|-----------|------------|
| 8 | | | | | | | | | | |
| 7 | | | | | | | | | | |
| 6 | SPRING | STEEL WIRE | 1 | NATURAL | WITHIN 1.5mm : $\pm 0.1mm$ | A | 2012-11-06 | 初版 | | |
| 5 | CONTACT CLIP | PBS C5210R-EH | 2 | Ag CLAD | OVER 1.5mm : $\pm 0.2mm$ | ISSUE | DATE | | | APPD. |
| 4 | BASE | PHENOLIC RESIN | 1 | NATURAL | TITLE : PUSH SWITCH | | | UNIT : mm | DRWG NO.: | |
| 3 | TERMINAL | BRASS STRIP | 6 | Ag PLATED OVER Ni PLATED | MODEL: | | | SCALE: 2:1 | | |
| 2 | FRAME | Electrolytic strip | 1 | NATURAL | 东莞市高迪电子有限公司 | | | DWN. | | 2012-11-06 |
| 1 | KNOB | PC | 1 | BLACK | | | | CHK'D | | 2012-11-06 |
| | | | | | | | | APPD. | | 2012-11-06 |