

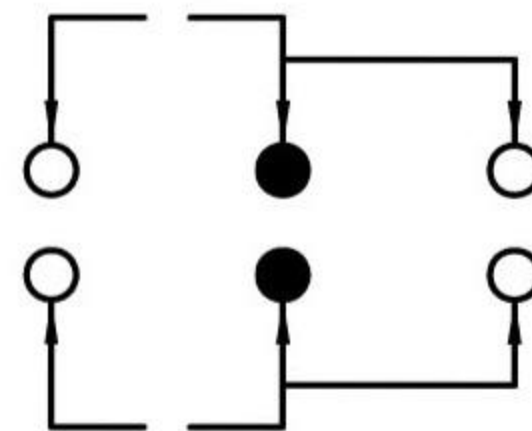

CAD FILE:

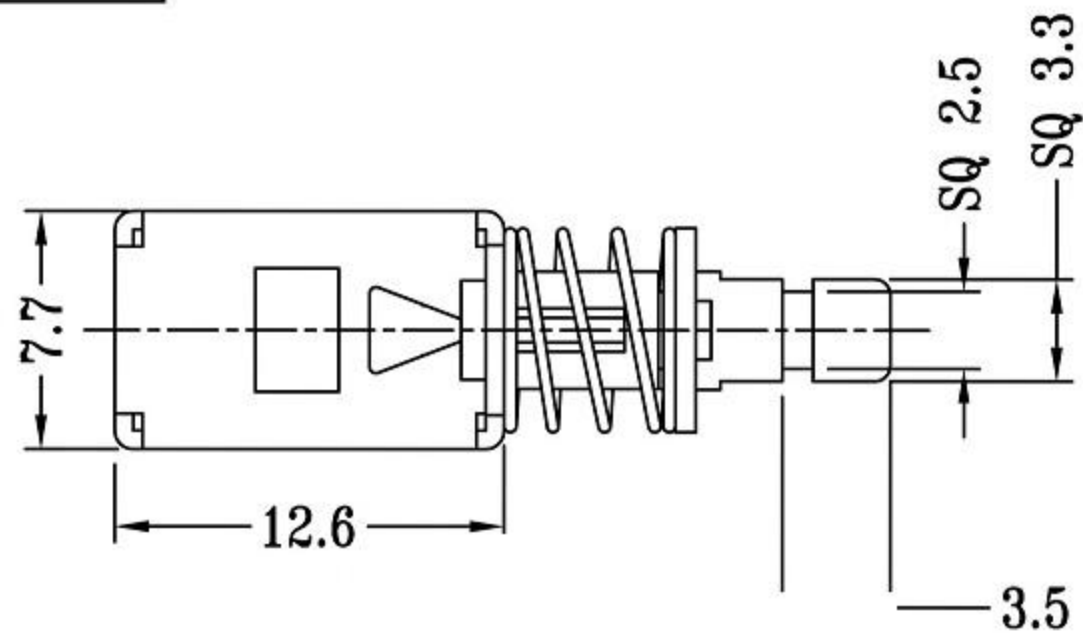

SCHEMATIC (NON-SHORTING)

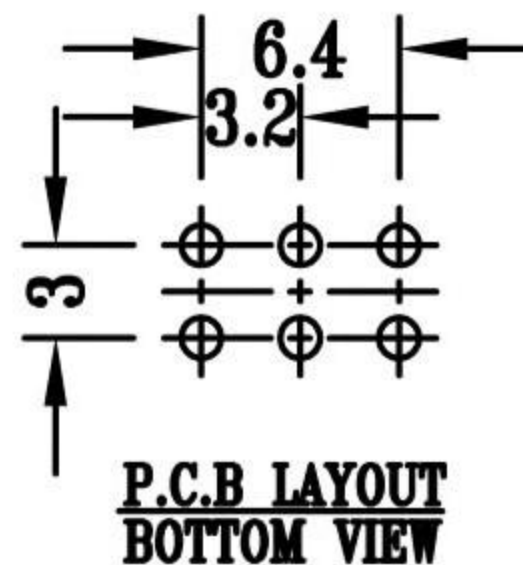
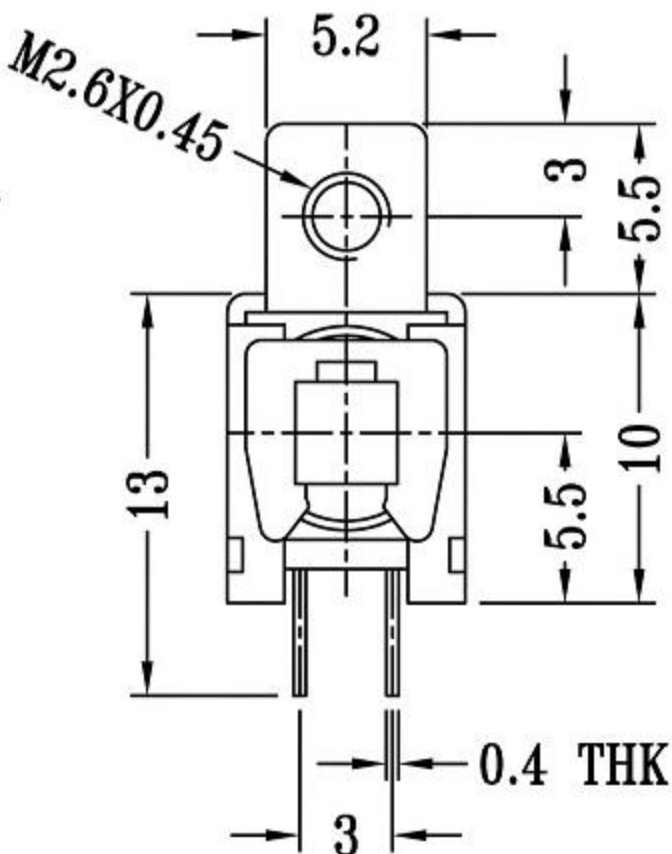
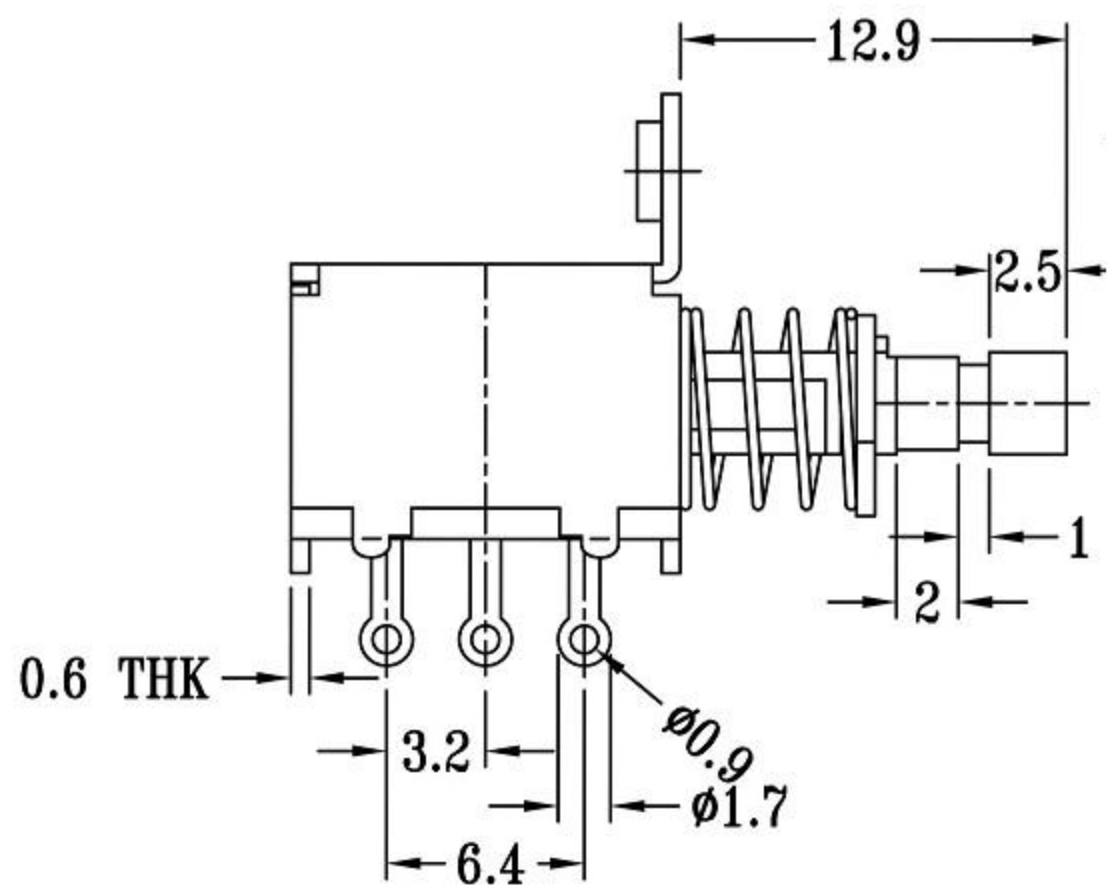

**P.C.B LAYOUT
BOTTOM VIEW**

按键开关技术参数:

1. 额定负荷: DC 30V 50V 0.1A 0.5A
2. 接触阻抗: $\leq 50m\Omega$
3. 绝缘阻抗: DC 250V $\geq 100m\Omega$
4. 耐焊温度: $250 \pm 5^\circ$ 5s
5. 使用寿命: 100,000 cycles
6. 使用温度: -25°C to 80°C
7. 使用湿度: $\leq 85\%$ RH
8. 操作力: $240gf \pm 80gf$
9. 功能选择: 自锁/无锁
10. 按压力可定制

NO.	PARTS	MATERIALS	Q'TY	FINISH	TOLERANCE UNLESS SPECIFIED		TITLE : PUSH SWITCH		UNIT : mm	DRWG NO.:	
8					WITHIN 1.5mm : $\pm 0.1mm$	A	2012-11-06			初版	
7					OVER 1.5mm : $\pm 0.2mm$	ISSUE	DATE			DESCRIPTIONS OF REVISION	
6	SPRING	STEEL WIRE	1	NATURAL						APPD.	
5	CONTACT CLIP	PBS C5210R-EH	2	Ag CLAD							
4	BASE	PHENOLIC RESIN	1	NATURAL							
3	TERMINAL	BRASS STRIP	6	Ag PLATED OVER Ni PLATED							
2	FRAME	Electrolytic strip	1	NATURAL							
1	KNOB	PC	1	BLACK							
					东莞市高迪电子有限公司						
										DWN.	2012-11-06
										CHK'D	2012-11-06
										APPD.	2012-11-06