

RoHS Compliant

Halogen Free

CUSTOMER DRAWING

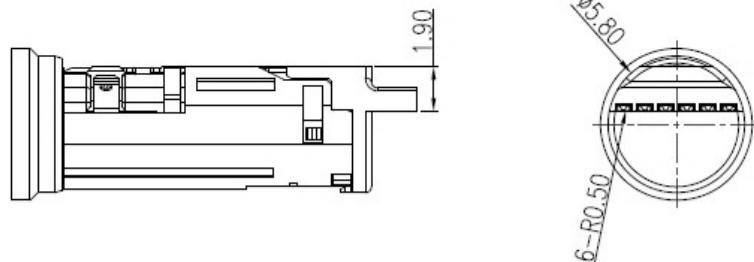
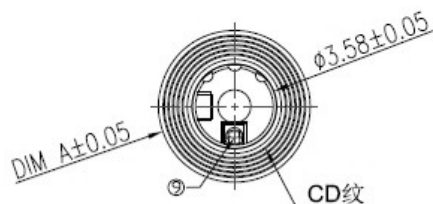
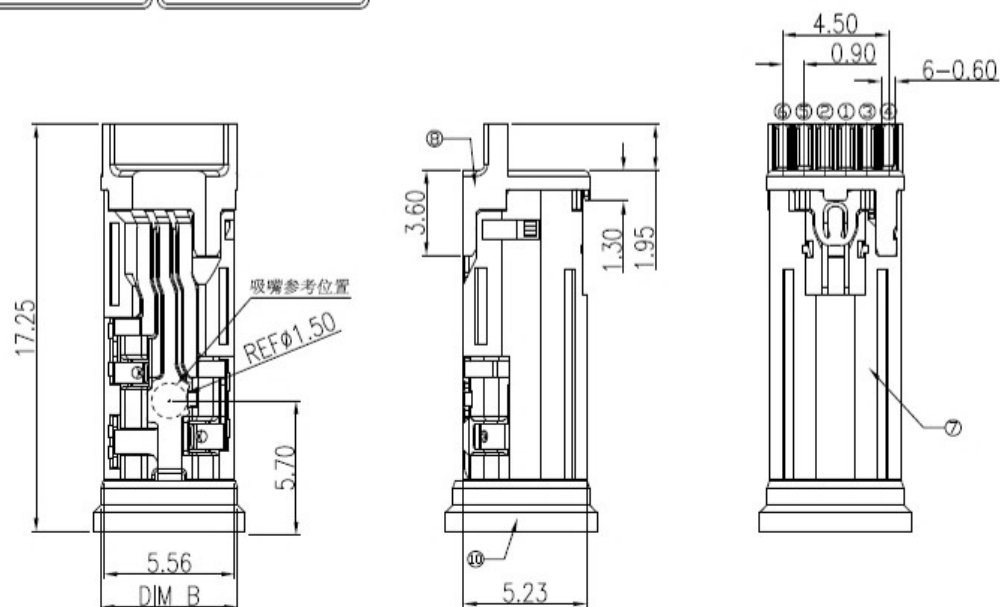
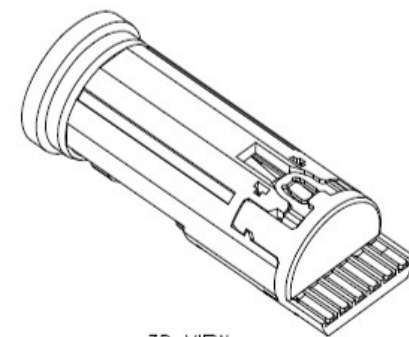

TABLE 2:

DIM A	DIM B	color
6.45	5.80	Black
6.45	5.80	White
6.45	5.80	Nature
6.00	5.60	Black
6.00	5.60	White
6.00	5.60	Nature



3D VIEW

NOTES:

- MATERIAL: SEE "TABLE 1";
- FINISH: SEE "TABLE 1";
- ELECTRICAL:
 - VOLTAGE RATING: 12 VAC RMS;
 - CURRENT RATING: 0.5 AMP;
 - CONTACT RESISTANCE: 50mΩ Max.(Initial), 100mΩ Max.(After Life test);
 - INSULATION RESISTANCE: 100 MΩ Min., 500VDC.(Initial), 50 MΩ Min., 500VDC.(After Humidity test);
 - WITHSTAND VOLTAGE: 500 VAC RMS 50(60)Hz, 1 minute;
- MECHANICAL:
 - MATING FORCE: 3.0Kgf MAX.;
 - UNMATING FORCE: 0.3Kgf MIN.;
 - OPERATING LIFE: 5000 CYCLES MIN.;
- ENVIRONMENTAL:
 - OPERATION: -30°C~+80°C.

TABLE 1:

NO.	PART NAME	QTY	MATERIAL	DESCRIPTION	REMARK
⑩	Ring	1	C3604	Nickel.PLATED	
⑨	Insulator	1	HIGH TEMP	Black	
⑧	Cover	1	HIGH TEMP	SEE "TABLE 2"	
⑦	Housing	1	HIGH TEMP	SEE "TABLE 2"	
⑥	Contact_6	⑥	COPPER ALLOY	Au G/F Min. PLATED T=0.20mm	
⑤	Contact_5	⑤	COPPER ALLOY	Au G/F Min. PLATED T=0.20mm	
④	Contact_4	④	COPPER ALLOY	Au G/F Min. PLATED T=0.20mm	
③	Contact_3	③	COPPER ALLOY	Au G/F Min. PLATED T=0.20mm	
②	Contact_2	②	COPPER ALLOY	Au G/F Min. PLATED T=0.20mm	
①	Contact_1	①	COPPER ALLOY	Au G/F Min. PLATED T=0.20mm	

UNLESS OTHERWISE, GENERAL TOLERANCE:
 X.xxx ±0.10
 X.xx ±0.20
 X.x ±0.30
 X. ±0.38
 ANGULAR:
 X.xx ±1'
 X.x ±3'
 X. ±5'

东莞市高迪电子有限公司

TITLE: φ3.5mm Phone Jack CONN. 客户图	P/N: SEE "TABLE 2"
MODEL:	DRAW NO.:
THIRD ANGLE PROJECTION	UNIT: mm
SCALE: 1:1	SIZE: A4
	SHEET: 1/1

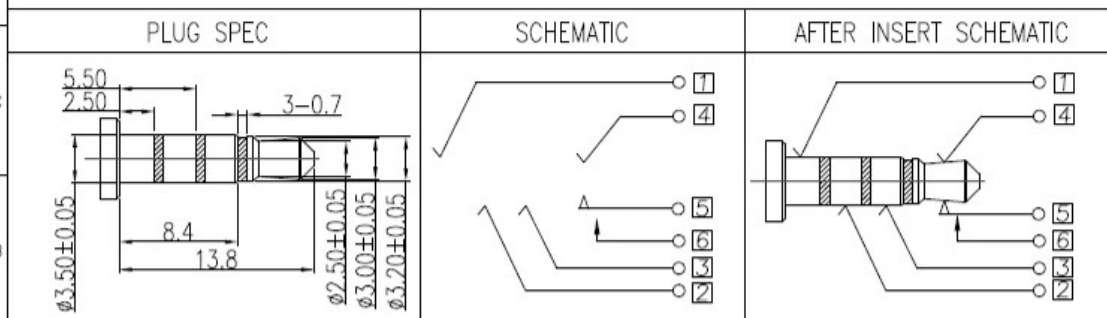

ECN NO.	REV.	DESCRIPTION	DATE	CHANGE	APPROVAL	吕海涛	2016.11.07
20161103003	X2	新增规格	2016.11.07	任翔	DESIGN	任翔	2016.11.07
JH2016-133	X1	结构变更, 新增颜色规格	2016.09.03	任翔	CHECK	郑小伟	2016.11.07
N/A	X	NEW DRAWING	2016.07.30	任翔	APPROVAL	吕海涛	2016.11.07