

MODEL NO.:

PJR-D31530- A □□□ AU02 L- RH

(1) (2) (3) (4) (5) (6)

- (1) Series no.
- (2) Schematic type: A
- (3) Housing color:
BK7=Black
GRG=Green
- (4) Terminal plating:
AU02=Plating AU 1" min.
- (5) Packing mode:L=Reel packing
- (6) Environmental requirements:
Rh=RoHS 2.0 + Halogen Free

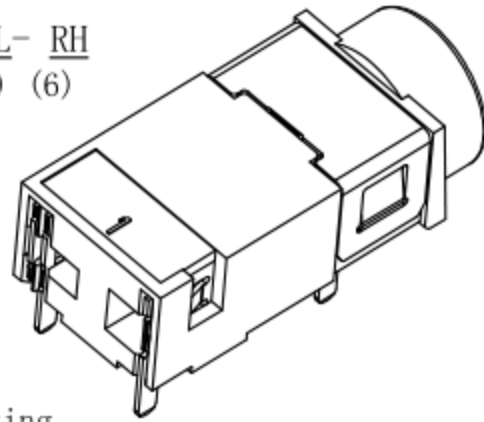

LOGO AND CAV NO

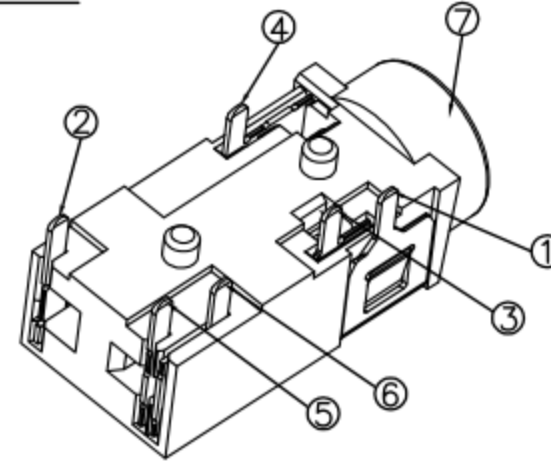
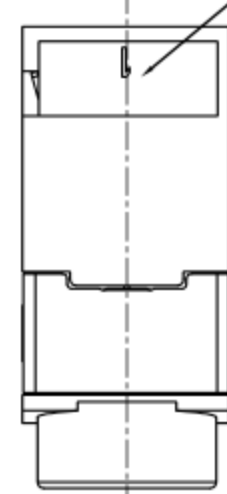

Matching Plug

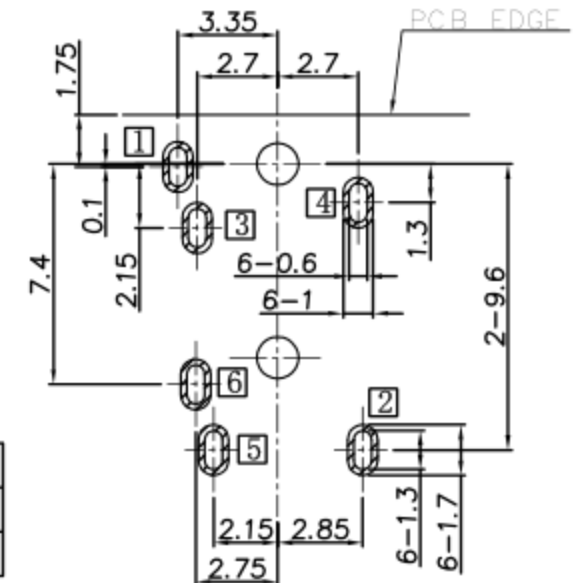
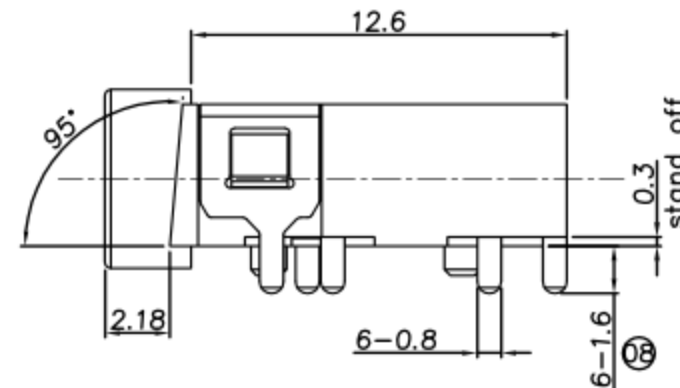
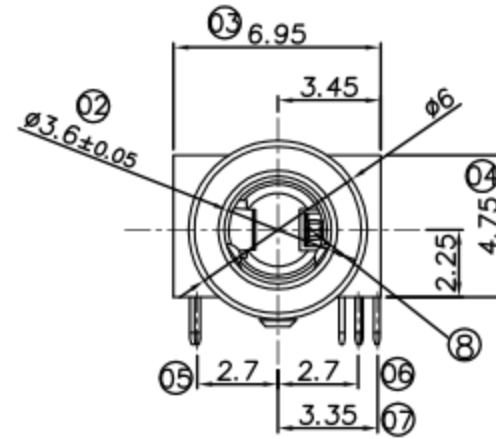
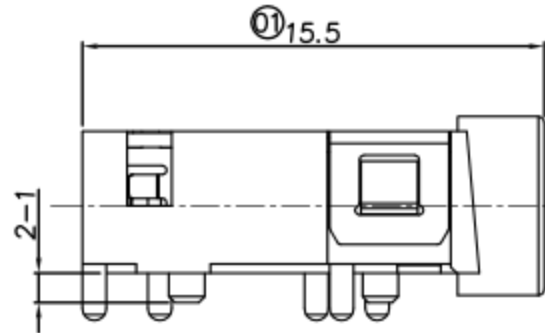
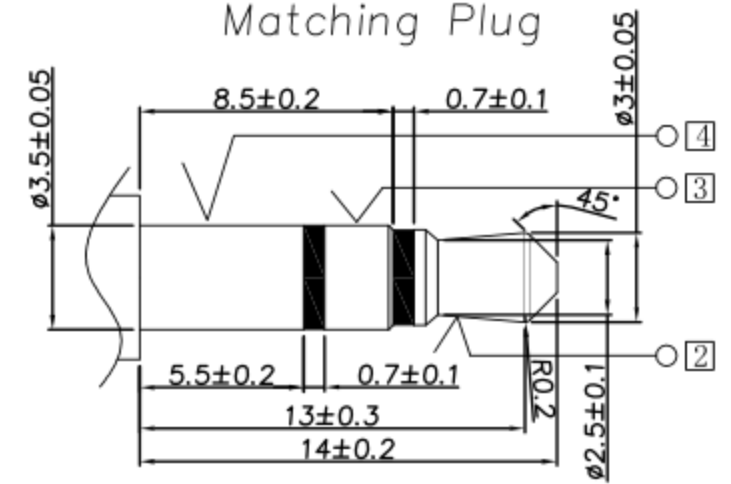

SPECIFICATION:

1. Electrical characteristics

- 1-1. Current rating:DC 1.0A.
- 1-2: Voltage rating:DC 12V.
- 1-3: Contact resistance:50mΩ max.
- 1-4. Insulation resistance:100MΩ min. at 500V DC.
- 1-5. Withstanding voltage:500V AC for 1 minute.

2. Mechanical characteristics

- 2-1. Life test:5000 cycles min,
- 2-2. Mating force:3~30N,
Unmating force:3~30N.

3. Salt spray test time:48 hours min.

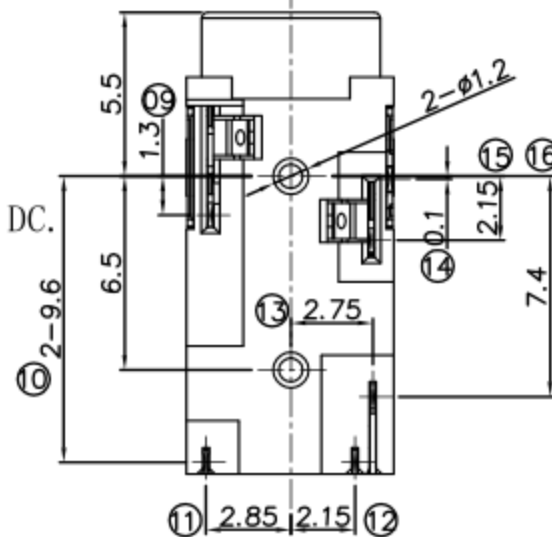
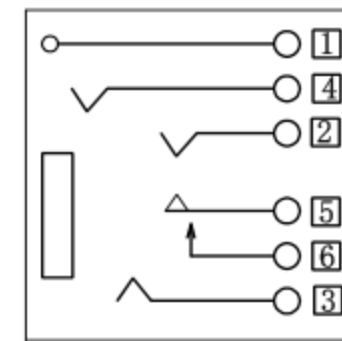

TABLE:

2	PJ-D31530-AGRGAU02L-RH	粉绿 (577C)
1	PJ-D31530-ABK7AU02L-RH	黑色
序号	适用物料编码	物料说明



Circuit Diagram

RECOMMENDED P. C. B LAYOUT
TOP VIEW (TOLRANCE: ±0.05)

NO.	DESCRIPTION	QTY	MATERIAL	REMARK
8	Insulator	1	PA10T R630NH+30%GF UL 94V-0	see table
7	Housing	1	PA10T R630NH+30%GF UL 94V-0	see table
6	Shunt	1	C5210R-EH, 0.20t	Gold Flash On Contact Area And Solder Tail, All over Nickel Plated
5	Transfer spring	1	C5210R-EH, 0.20t	
4	Ring spring	1	C5210R-EH, 0.20t	
3	Ring spring	1	C5210R-EH, 0.20t	
2	Tip spring	1	C5210R-EH, 0.20t	
1	Earth spring	1	C5191R-H, 0.20t	

ECN NO.	REV	DATE	DESCRIPTION	CHANGE	APPRO.	GENERAL TOLERANCE UNLESS OTHERWISE NOTED	SCALE: 3:1	UNIT:mm	A4	SHEET:1 of 1	东莞市高迪电子有限公司	
	A-0	2014. 12. 24	NEW	王朝荣	余军	Angle ±2° 10<L≤20 ±0.3 5<L≤10 ±0.25 L≤5 ±0.20					TITLE: φ3.5mm PHONE JACK	
											MODEL NO. PJR-D31530-A□□□AU02L- RH	
											FILE NO. Q/SSY. QW-001A-0496	