

SPECIFICATION:

1. Electrical characteristics
 - 1-1. Current rating: 0.5Amps.
 - 1-2. Voltage rating: 30V DC.
 - 1-3. Contact resistance: 30mΩ max; After test: 50mΩ max.
 - 1-4. Insulation resistance: 100MΩ min. at 500V DC. After test: 50MΩ min.
 - 1-5. Withstanding voltage: 500V AC
2. Mechanical characteristics
 - 2-1. Life test: 5000 cycles min,
 - 2-2. Mating force: 3~30N. Unmating force: 8~30N. After test: 5~30N
3. Operating Temperatures: -20°C~+70°C
Preservative temperature range: -40°C~+85°C

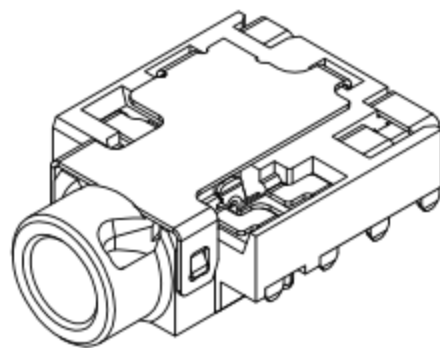
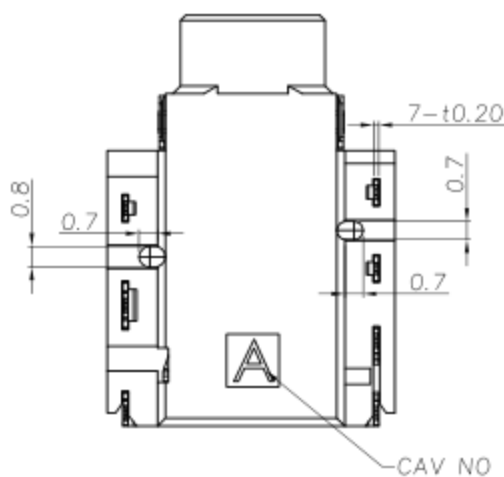

⑨	Insulator	1	PA10T UL94 V-0	Black
⑧	Housing	1	PA10T UL94 V-0	Black
⑦	Shell		C5210, 0.20t	Nickel 50u" Plating
⑥	Shunt terminal	⑥	C5210, 0.20t	Gold Flash On Contact Area and Solder Tail Area, All over 50u" Nickel Plated
⑤	Transfer Spring	⑤	C5210, 0.20t	
④	Ring spring	④	C5210, 0.20t	
③	Ring spring	③	C5210, 0.20t	Gold Flash On Contact Area and Solder Tail Area, All over 50u" Nickel Plated
②	Tip spring	②	C5210, 0.20t	
①	Earth spring	①	C5210, 0.20t	
NO.	DESCRIPTION	QTY	MATERIAL	REMARK

					Angle	±2°	DESIGN	罗振强	2021. 05. 18
					. x	±0.35	CHECK		
					. xx	±0.25	APPROVAL		
					. xxx	±0.10			
ECN NO.	REV	DATE	DESCRIPTION	CHANGE	APPRO.	GENERAL TOLERANCE UNLESS OTHERWISE NOTED	SCALE: 1:1	UNIT:mm	A4

东莞市高迪电子有限公司

CUSTOMER DRAWING
 TITLE: φ3.5mm PHONE JACK
 MODEL NO. PJR-D3144A-ABK7AU02L-RH
 FILE NO. Q/DY. QW-001A-0745