

CUSTOMER DRAWING

所有物质均符合环保要求

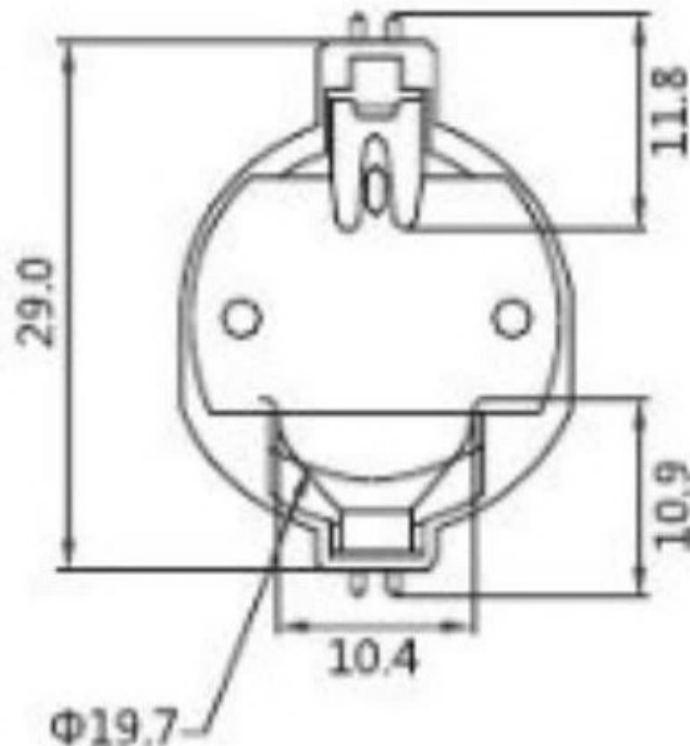
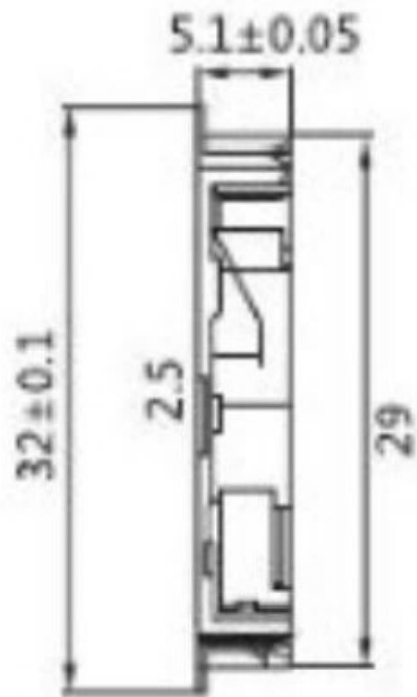

NOTE:

1. MATERIAL:
  - a. HOUSING: THERMOPLASTIC GLASS FIBRE UL94V-0
  - b. CONTACT: BRASS
2. ELECTRIC:
  - a. CONTACT RESISTANCE: 30 MILLIOHMS MAX
  - b. INSULATION RESISTANCE: 1000 MEGA OHMS MIN
  - c. DIELECTRIC VOLTAGE: 750V AC ONE SEC LEVEL
  - d. OPERATING TEMPERATURE: -55 ~C ~ +85 ~C

NO.	PART NAME	QTY	MATERIAL	DESCRIPTION	REMARK
③	SPRING	1	STAINLESS STEEL	Ni PLATED	
②	TERMINAL	1	COPPER ALLOY	Au PLATED	
①	Housing	1	HIGH TEMP	Black	

UNLESS OTHERWISE,  
GENERAL TOLERANCE:  
X.xxx ±0.10  
X.xx ±0.20  
X.x ±0.30  
X. ±0.38  
ANGULAR:  
X.xx ±1°  
X.x ±3°  
X. ±5°

**东莞市高迪电子有限公司**

TITLE: 电池座卧式		P/N:	
客户图		MODEL:	
THIRD ANGLE PROJECTION		UNIT: mm	SCALE: 1:1
		SIZE: A4	SHEET: 1/1

ECN NO.	REV.	DESCRIPTION	DATE	CHANGE	APPROVAL	DATE
JH2016-061	E	修改图面与实物相符	2016.05.31	BIn	DESIGN 陈少兵	2016.05.31
	D	更新图面	2015.09.23	陈少兵	CHECK 郑小伟	2016.05.31
	C	调整尺寸公差	2013.07.04	陈少兵	APPROVAL 吕海涛	2016.05.31