

RoHS  
Compliant

ZONE	SYMBOL	REVISION	APPROVAL	DATE
A		INITIAL	Lucky	06/20/20'

- SPECIFICATIONS:**
- 1.RATING: 12V, 1A .
  - 2.CONTACT RESISTANCE:30mΩ OR LESSFOR INITIAL
  - 3.VOLTAGE PROOF:500V AC FOR ONE MINUTE
  - 4.DURABILITY:5,000 INSERTION/EXTRACTION CYCLES
  - 5.INSETION FORCE:3.0KG MAX
  - 6.WITHDRAWAL FORCE:0.3KG MIN
  - 7.WATER PROOFNESS: THIS PRODUCT IS BASED ON IPX7(1m,30min)
  - 8.USING PLUG: φ3.5MM、3-POLE STEREO
  9. OVAL RING  
9-1. Hardness of silicone rubber:70°  
9-2. Horizontal flash 0.10mm max;Longitudinal flash 0.10mm max
  - 10.HOUSING WITH O-RING'S SEAL AREA BURRS IS 0.05mm MAX.
  - 11.FOR REFLOW SOLDERING LEAD-FREE PROCESS.
  - 12.PACKAGING: TAPE & REEL.

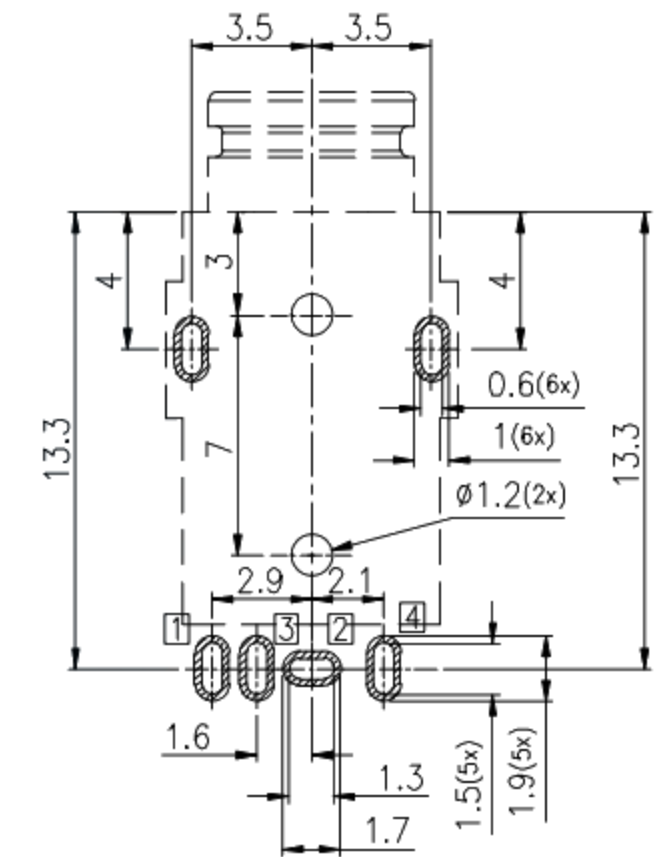
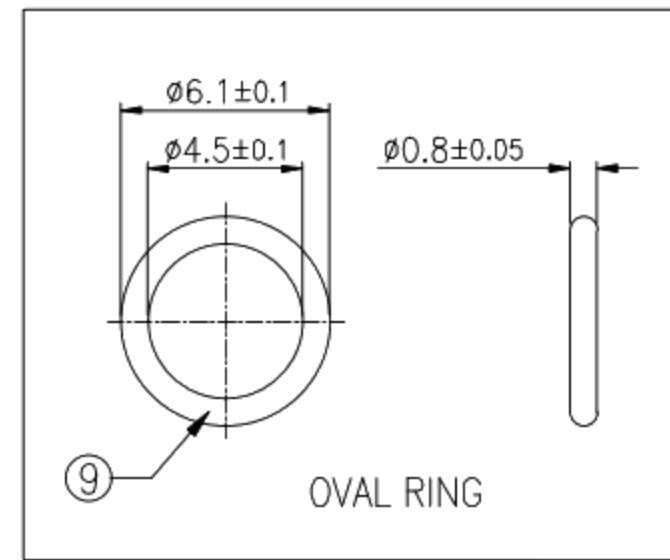
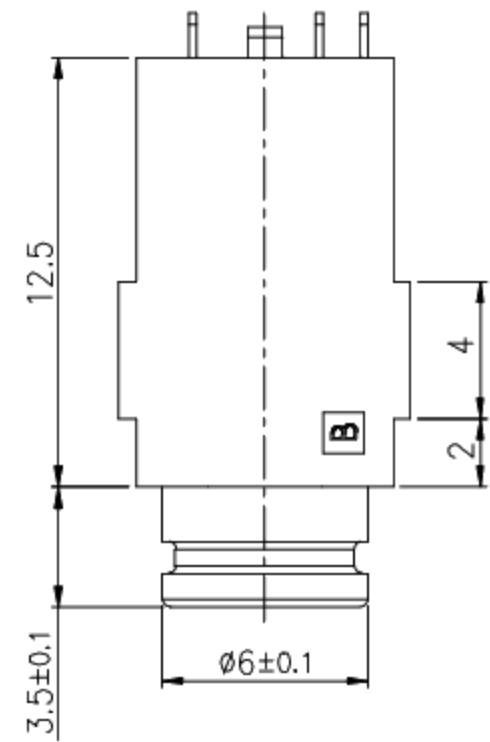

Recommended PCB Layout(T=1.2)  
Tolerance: ±0.05(TOP view)

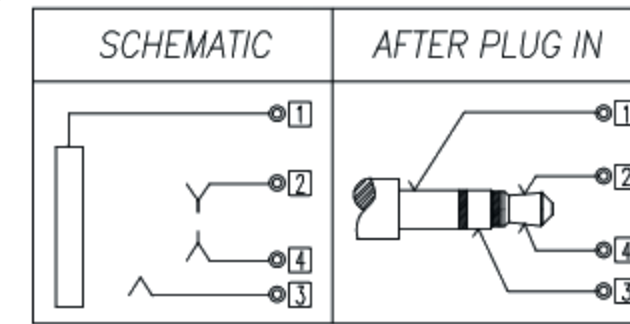
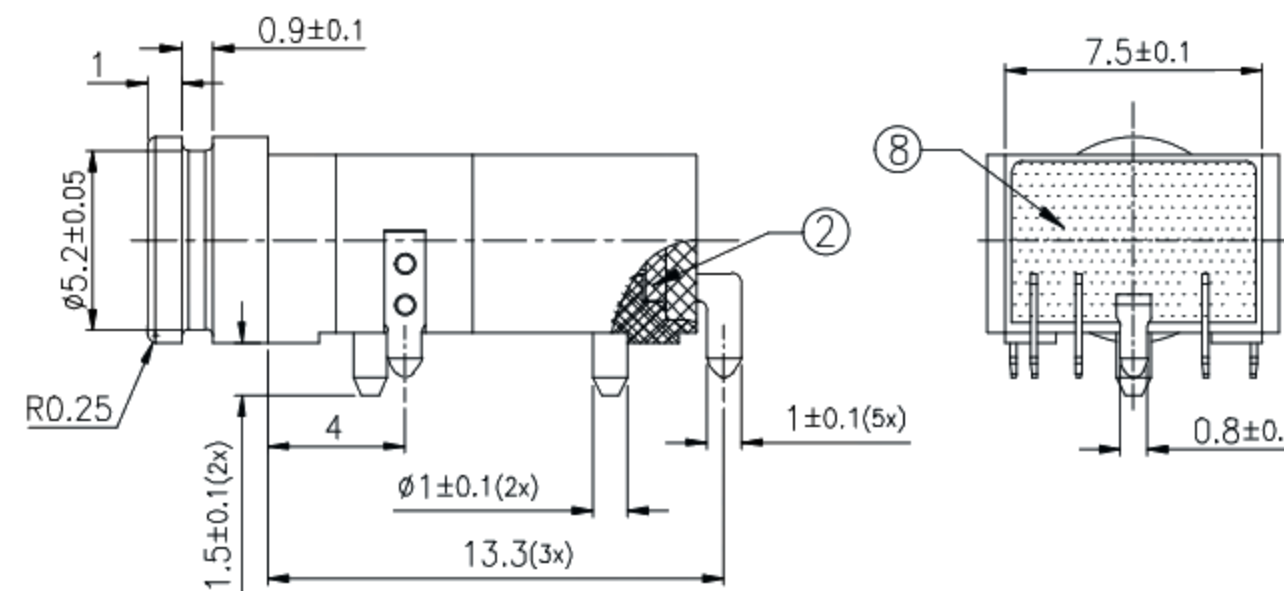
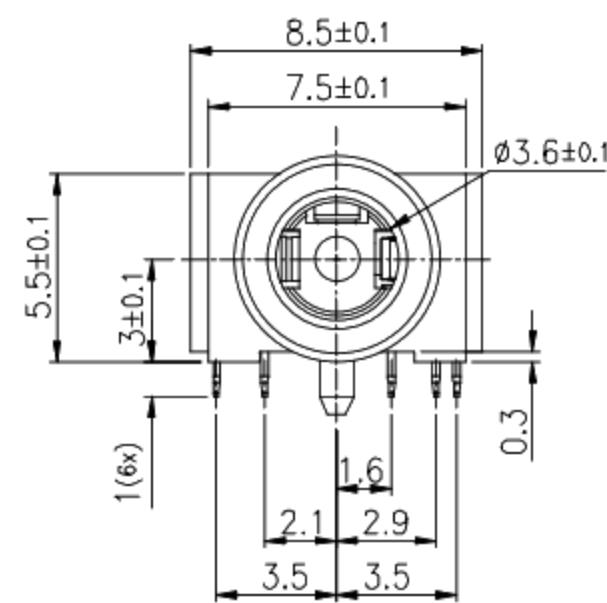

□ : TERMINAL NO.

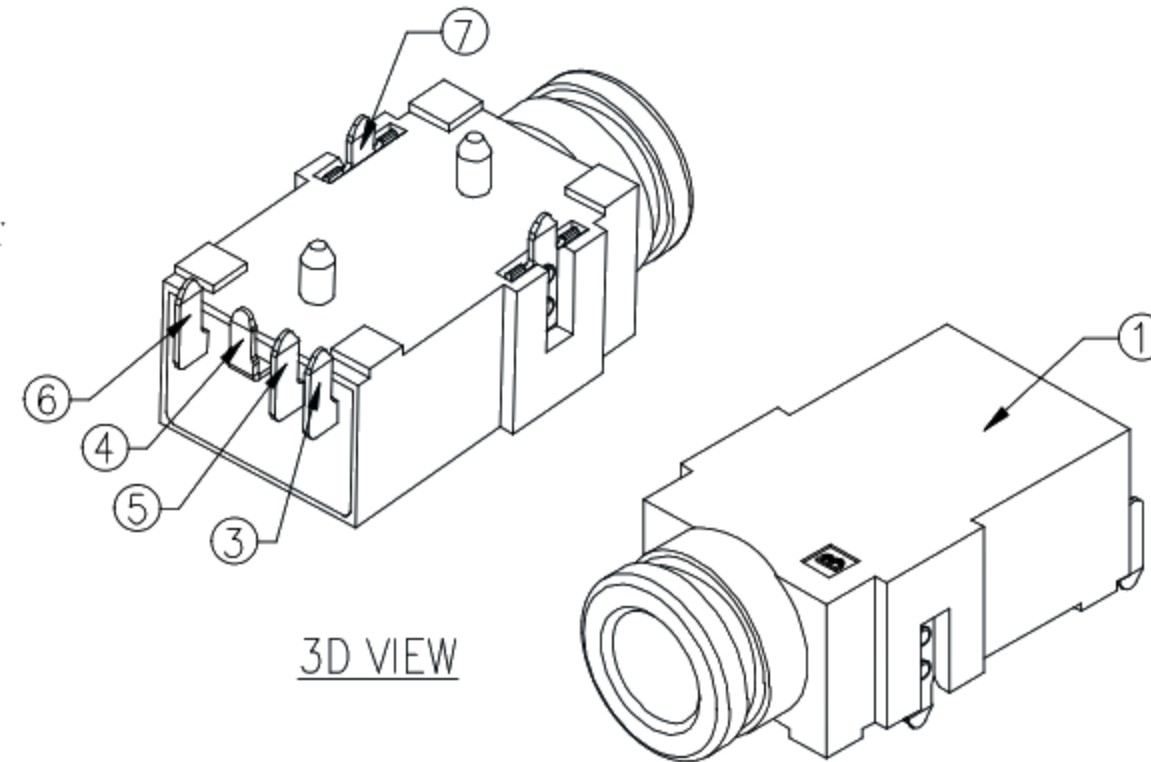
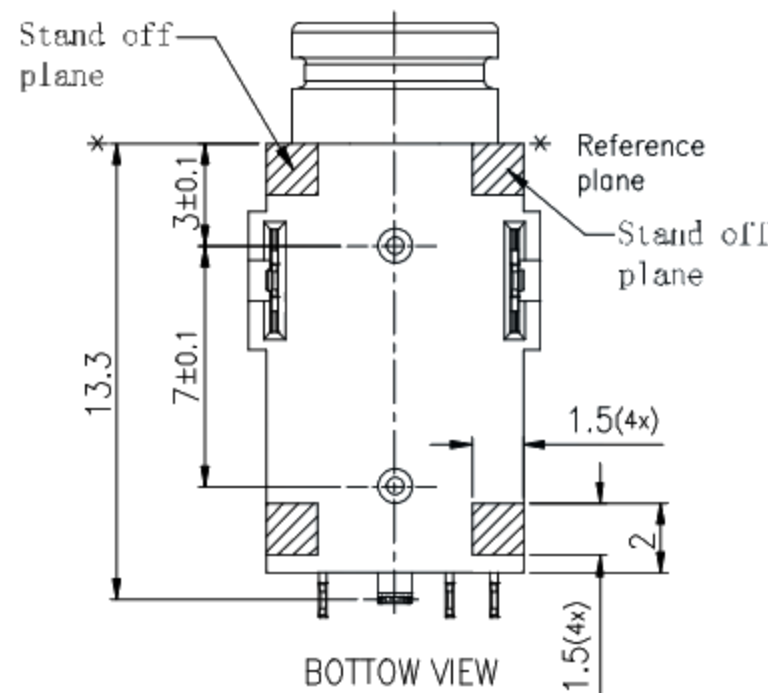

ITEM	PART NAME	TERMINAL	QTY	MATERIAL	REMARK
⑨	OVAL RING	----	1	SILICONE	GREEN
⑧	BOND	----	1	EPOXY	----
⑦	TERMINAL	----	2	C2680R-H T=0.2	Matte Sn 80u" Min; Ni 40u" Min underplate
⑥	TIP SPRING-2	④	1	C5210R-EH T=0.2	
⑤	RING SPRING	③	1	C5210R-EH T=0.2	
④	TIP SPRING-1	②	1	C5210R-EH T=0.2	
③	EARTH SPRING	①	1	C5210R-EH T=0.2	
②	COVER	----	1	PA9T+33%GF(GN2330)	UL 94V-0
①	HOUSING	----	1	PA9T+33%GF(GN2330)	UL 94V-0

**东莞市高迪电子有限公司**

DRAWING:	Lucky	DATE:	2020.20.06	SCALE	5:1
CHECK:	liao Y K	DATE:	2020.20.06	MATERIAL	*
APPROVAL:	Abel	DATE:	2020.20.06	DWG. no.	A
DRAWING NO.				SHEET	1/1

PART NAME	3.5mm STEREO JACK	TOLERANCE UNLESS	0.0±0.2	UNIT:	mm
PART NO.		OTHERWISE SPECIFIED:	0.00±0.1 0.000±0.05		