

PROPRIETARY INFORMATION
COMPANY CONFIDENTIAL

| | | | | |
|------|---------|-------------|--------|------------|
| REV. | ECN NO. | DESCRIPTION | DESIGN | DATE |
| A | | INITIAL | Kai | 2018.05.11 |

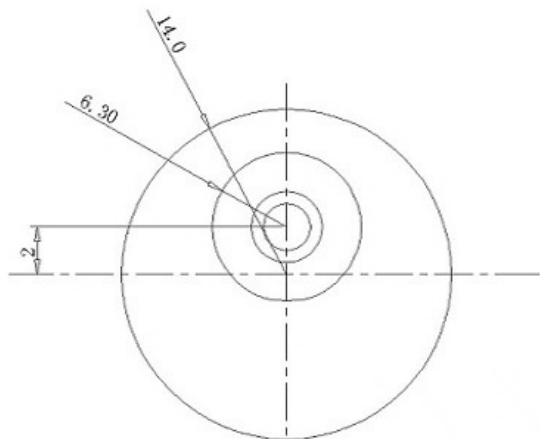

P.C.B LAYOUT

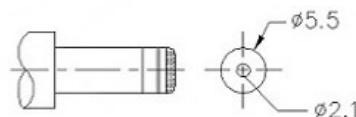
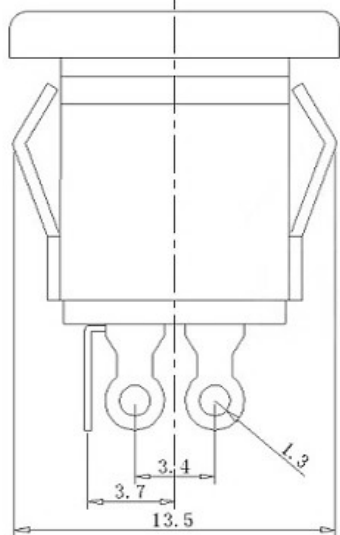
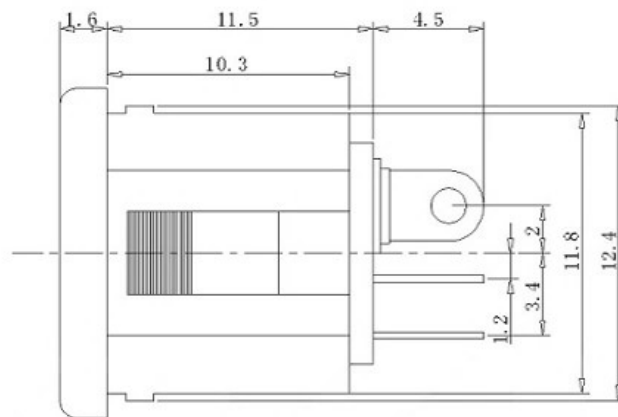
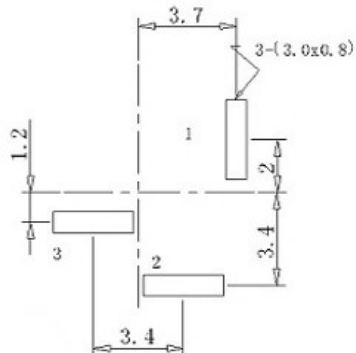

MATING PLUG
Jack Insertion Depth: 9.15 mm

| | |
|------------|---------|
| SCHEMATIC | |
| Center Pin | Ø2.0 mm |
| | Ø2.5 mm |

SPECIFICATIONS:

- ELECTRICAL CHARACTERISTICS:
 - RATING: 24V 3A
 - CONTACT RESISTANCE: 30mΩ MAX.(INITIAL)
 - DIELECTRIC WITHSTANDING VOLTAGE: 500V AC FOR ONE MINUTE
 - INSULATION RESISTANCE: 100M MIN. MEASURED BY 500V DC
- MECHANICAL CHARACTERISTICS:
 - INSERTION FORCE : 0.3~3.0 KGF
 - WITHDRAWAL FORCE : 0.3~3.0 KGF
- LIFE TEST: 5,000 CYCLES MIN.
- FOR REFLOW SOLDERING LEAD-FREE PROCESS.

| ITEM | NAME | Q'TY | DESCRIPTION | NOTE |
|------|-------------|------|--|------|
| 3 | SHELL | 1 | PHORPHOS BRONZE; THE BOTTOM OF THE NICKEL(40u*MIN.); THE WHOLE GOLD FLASH PLATING. | |
| 2 | CONCTOR PIN | 1 | BRASS; THE BOTTOM OF THE NICKEL(40u*MIN.); THE WHOLE GOLD FLASH PLATING. | |
| 1 | HOUSING | 1 | PA9T COLOR BLACK | |

| | | | |
|---------------------------------------|-------|---------|-----|
| UNLESS OTHERWISE SPECIFIED TOLERANCES | | | |
| DECIMALS: | | ANGLES: | |
| DIM | TOL | DIM | TOL |
| X. | ±0.50 | X. | ±2' |
| X.X | ±0.30 | X.X | ±1' |
| X.XX | ±0.20 | X.XX | — |
| X.XXX | ±0.10 | X.XXX | — |

东莞市高迪电子有限公司

| | |
|----------|-------------------------------|
| DWG NO. | PART NAME: DC POWER JACK |
| DESIGN: | PART NO. |
| CHECK: | REV. UNIT: SHEET: A mm 1/1 |
| APPROVED | |