

PROPRIETARY INFORMATION
COMPANY CONFIDENTIAL

REV.	ECN NO.	DESCRIPTION	DESIGN	DATE
A		INITIAL	Kai	2018.05.11

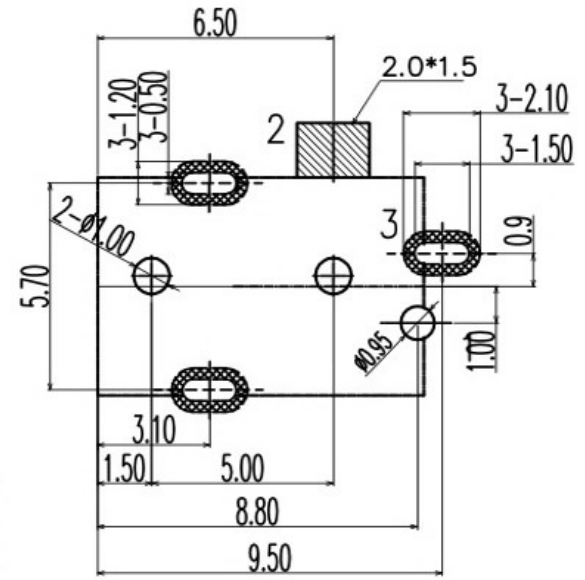

P.C.B. LAYOUT
TOP VIEW

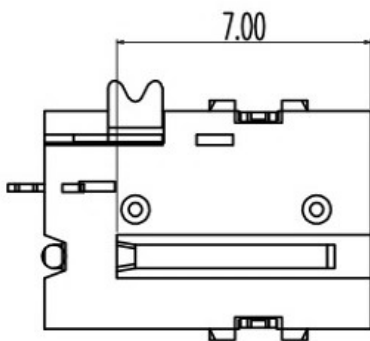
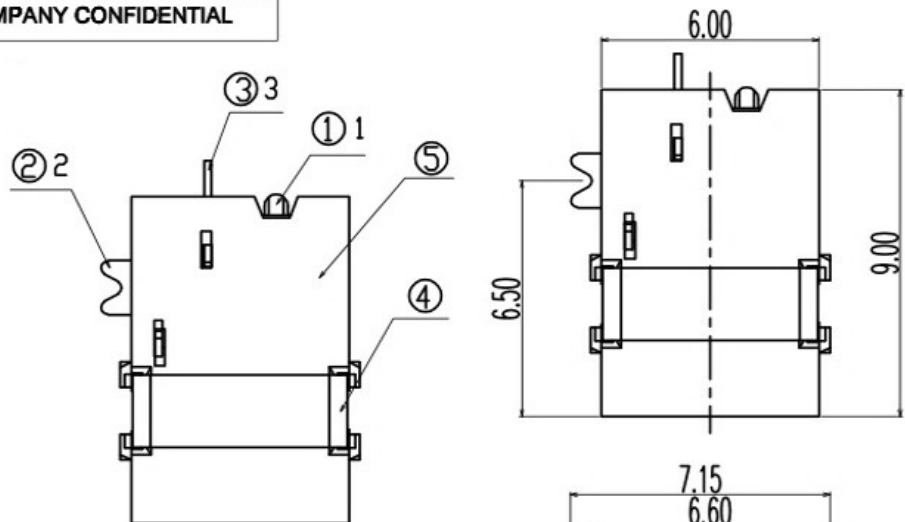
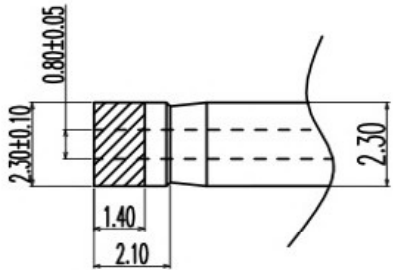
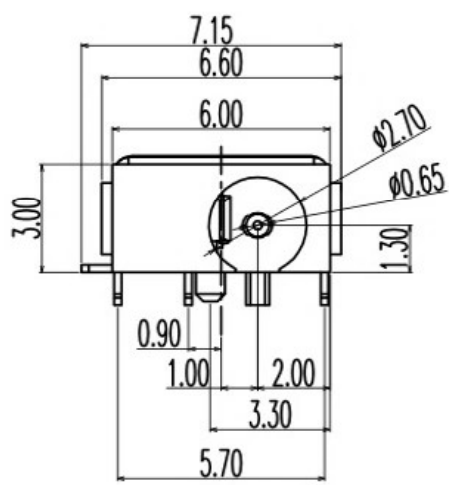
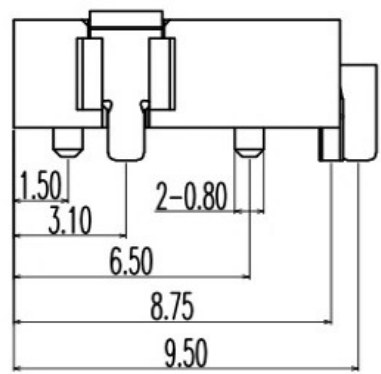

(DC PLUG)

SPECIFICATIONS:

- ELECTRICAL CHARACTERISTICS:
 - 1-1. RATING: 24V 3A
 - 1-2. CONTACT RESISTANCE: 30mΩ MAX.(INITIAL)
 - 1-3. DIELECTRIC WITHSTANDING VOLTAGE: 500V AC FOR ONE MINUTE
 - 1-4. INSULATION RESISTANCE: 100M MIN. MEASURED BY 500V DC
- MECHANICAL CHARACTERISTICS:
 - 2-1. INSERTION FORCE : 0.3~3.0 KGF
 - 2-2. WITHDRAWAL FORCE : 0.3~3.0 KGF
- LIFE TEST: 5,000 CYCLES MIN.
- FOR REFLOW SOLDERING LEAD-FREE PROCESS.

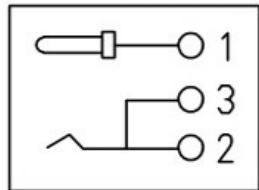

SCHEMATIC

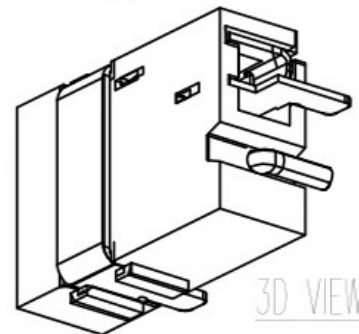

3D VIEW

ITEM	NAME	Q'TY	DESCRIPTION	NOTE
3	SHELL	1	PHORPHOS BRONZE; THE BOTTOM OF THE NICKEL(40u"MIN.); THE WHOLE GOLD FLASH PLATING.	
2	CONCTOR PIN	1	BRASS; THE BOTTOM OF THE NICKEL(40u"MIN.); THE WHOLE GOLD FLASH PLATING.	
1	HOUSING	1	PA9T COLOR BLACK	

UNLESS OTHERWISE SPECIFIED TOLERANCES			
DECIMALS:		ANGLES:	
DIM	TOL	DIM	TOL
X.	±0.50	X.	±2'
X.X	±0.30	X.X	±1'
X.XX	±0.20	X.XX	—
X.XXX	±0.10	X.XXX	—

东莞市高迪电子有限公司

DWG NO.		PART NAME: DC POWER JACK	
DESIGN:		PART NO.	
CHECK:		REV.	UNIT: mm
APPROVED		SHEET:	1/1

由 Autodesk 教育版产品制作

由 Autodesk 教育版产品制作