

REV.	ECN NO.	DESCRIPTION	DESIGN	DATE
A		INITIAL	Lucky	04/19/2018

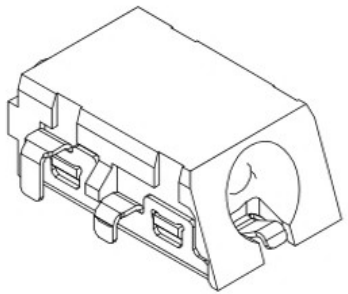

**3D VIEW**

- SPECIFICATIONS:
- ELECTRICAL CHARACTERISTICS:
    - RATING: 24V 3A
    - CONTACT RESISTANCE: 30mΩ MAX.(INITIAL)
    - DIELECTRIC WITHSTANDING VOLTAGE: 500V AC FOR ONE MINUTE
    - INSULATION RESISTANCE: 100MΩ MIN. MEASURED BY 500V DC
  - MECHANICAL CHARACTERISTICS:
    - INSERTION FORCE : 0.3~3.0 KGF
    - WITHDRAWAL FORCE : 0.3~3.0 KGF
  - LIFE TEST: 5,000 CYCLES MIN.

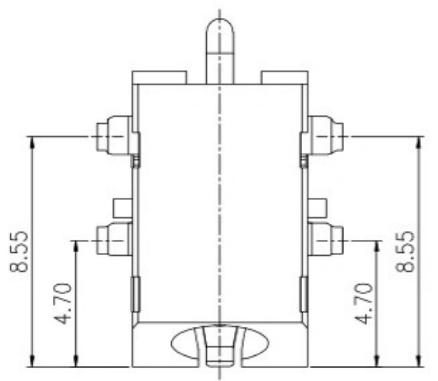
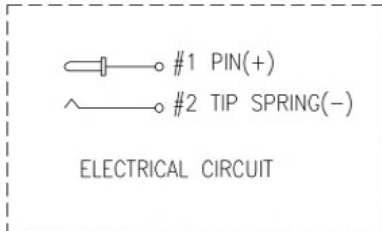
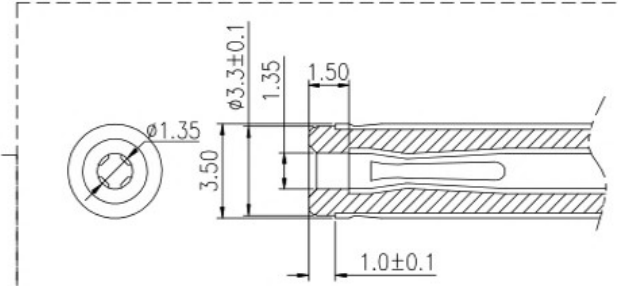
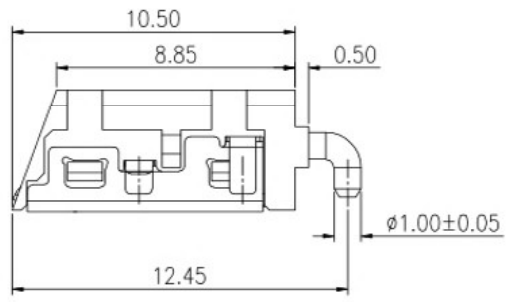
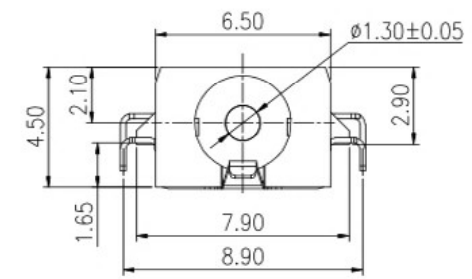

**MATE PLUG**

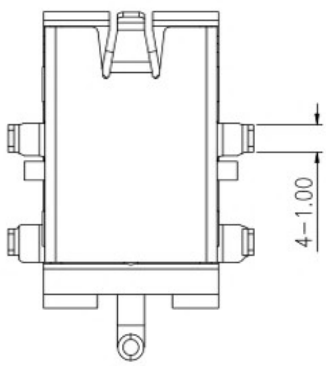
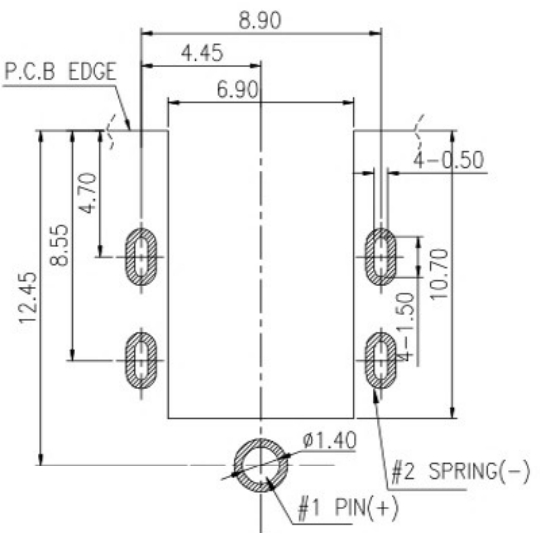

③	CENTER PIN	1	BRASS $\phi$ 1.3	Au
②	TERMINAL	2	PHOSPHOR BRONZE 0.2t	Au
①	HOUSING	1	PA-10T	Black
NO.	DESCRIPTION	QTY	MATERIAL	PLATING & COLOR

UNLESS OTHERWISE SPECIFIED TOLERANCES

**东莞市高迪电子有限公司**

DECIMALS:	ANGLES:	DWG NO.	PART NAME:
DIM TOL	DIM TOL	DESIGN:	DC POWER JACK
X. ±0.50	X. ±2°	CHECK:	PART NO.
X.X ±0.30	X.X ±1°	APPROVED	REV. A
X.XX ±0.20	X.XX		UNIT: mm
X.XXX ±0.10	X.XXX		SHEET: 1/1

Autodesk 教育版产品制作

Autodesk 教育版产品制作