

REV.	ECN NO.	DESCRIPTION	DESIGN	DATE
A		INITIAL	Kai	2018.05.08

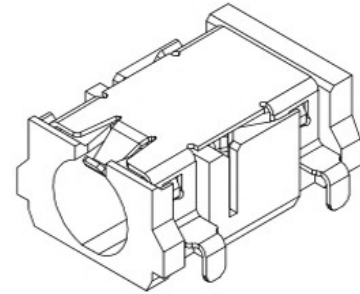

3D VIEW

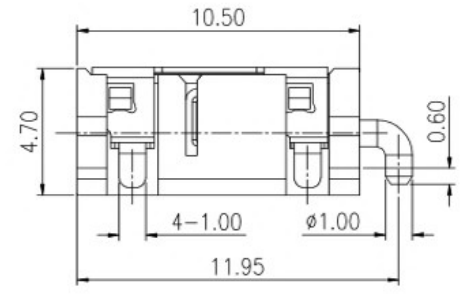
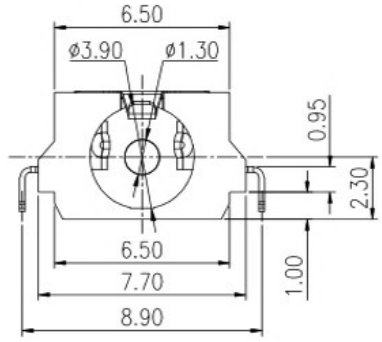
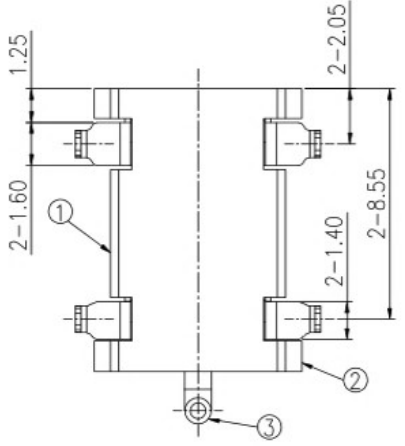

ELECTRICAL CIRCUIT

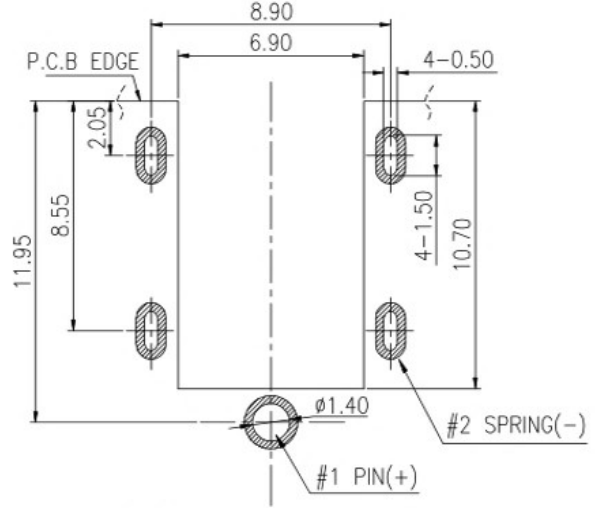

RECOMMENDED PCB LAYOUT
TOP VIEW (TOLERANCE:±0.05)

SPECIFICATIONS:

- ELECTRICAL CHARACTERISTICS:
 - RATING: 24V 3A
 - CONTACT RESISTANCE: 30mΩ MAX.(INITIAL)
 - DIELECTRIC WITHSTANDING VOLTAGE: 500V AC FOR ONE MINUTE
 - INSULATION RESISTANCE: 100MΩ MIN. MEASURED BY 500V DC
- MECHANICAL CHARACTERISTICS:
 - INSERTION FORCE : 0.3~3.0 KGF
 - WITHDRAWAL FORCE : 0.3~3.0 KGF
- LIFE TEST: 5,000 CYCLES MIN.
- FOR REFLOW SOLDERING LEAD-FREE PROCESS.

NO.	DESCRIPTION	QTY	MATERIAL	PLATING & COLOR
③	CENTER PIN	1	BRASS ϕ 1.3	Au
②	TERMINAL	1	PHOSPHOR BRONZE 0.2t	Au
①	HOUSING	1	PPA	Black

UNLESS OTHERWISE SPECIFIED TOLERANCES

东莞市高迪电子有限公司

DECIMALS:		ANGLES:		DWG NO.	PART NAME:
DIM	TOL	DIM	TOL	DESIGN:	DC电源插座
X.	±0.50	X.	±2'	CHECK:	PART NO.
X.X	±0.30	X.X	±1'	APPROVED	REV. UNIT: SHEET:
X.XX	±0.20	X.XX	—	A mm 1/1	
X.XXX	±0.10	X.XXX	—		

由Autodesk 教育版产品制作

Autodesk (TM) & Inventor (TM)