

CAD FILE:

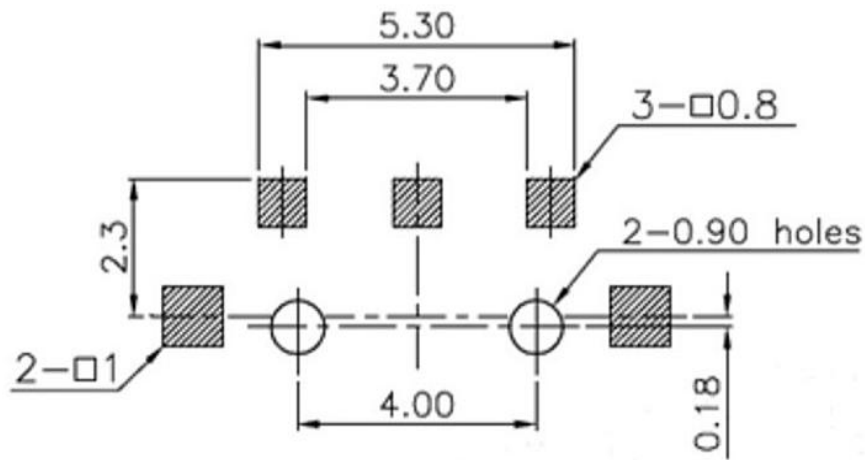

PCB Layout (Pattern side)

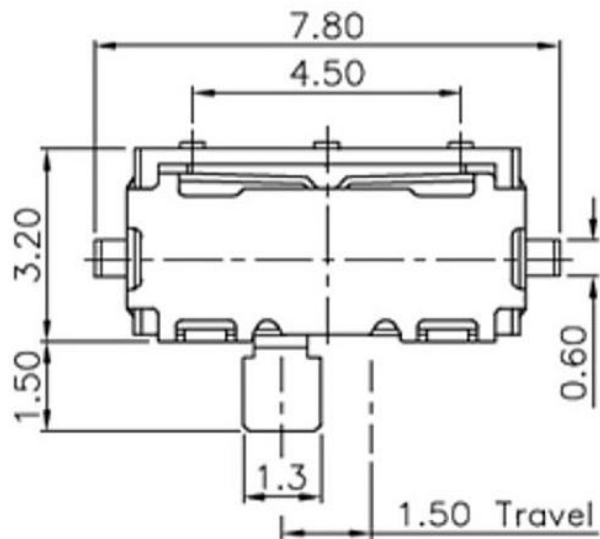
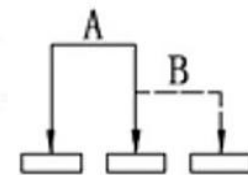

Circuit Diagram
C: Common Pin

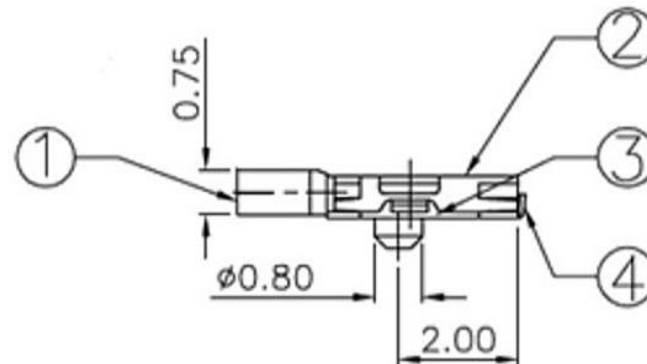
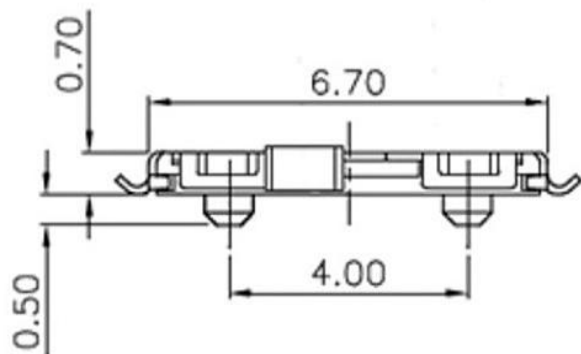

注: "*"表示关键尺寸(6个)

NO.	PARTS	MATERIALS	Q'TY	FINISH	TOLERANCE			
8					UNLESS SPECIFIED			
7	STEEL BALL	STEEL	1	NATURAL	WITHIN	A	2012-10-26	初版
6	SPRING	STEEL WIRE	1	NATURAL	OVER	ISSUE	DATE	DESCRIPTIONS OF REVISION
5	CONTACT CLIP	PBS STRIP	2	Ag PLATED	TITLE : SLIDE SWITCH			
4	TERMINAL	BRASS STRIP	8	Ag PLATED	MODEL:		UNIT : mm	DRWG NO.:
3	BASE	PHENOLIC RESIN	1	NATURAL			SCALE: 3:1	DWN.
2	FRAME	STEEL STRIP	1	Ni PLATED				2012-10-26
1	KNOB	POM	1	BLACK				CHK'D
								2012-10-26
								APPD.



東莞市高迪電子有限公司
DONGGUAN GAODI ELECTRONICS CO., LTD.