

电流电路  
CURRENT CIRCUIT

CIRCUIT:002

位置 POSITION	电路 CIRCUIT
1(INITIAL)起始	OFF
2	C+1

# 两档滑动开关

- 滑动开关型号 SLIDE SWITCH MODEL: KND-1-DF002
- 焊线端子 SOLDER CONNECTOR TYPE;  
单刀双掷 . 多回路 SINGLE POLE DOUBLE THROW;
- 额定值 RATING: 16(4)A 125/250VAC  $\mu$ T105  
10(2)A 125/250VAC  $\mu$ T85  
7(2)A 125/250VAC  $\mu$ T85  
5(1)A 125/250VAC  $\mu$ T85  
CQC N 17 RoHS
- 接触电阻 CONTACT RESISTANCE: <50m $\Omega$  (INITIAL)
- 绝缘电阻 INSULATION RESISTANCE:  $\geq$ 100M $\Omega$ (DC500V/1MIN)
- 介电强度 DIELECTRIC STRENGTH: 1500V /5mA /1MIN
- 机械寿命 MECHANICAL LIFE: >100000 CYCLES
- 电气寿命 ELECTRICAL LIFE: >50000 CYCLES
- 端子手工焊接条件 SOLDER ABILITY OF TERMINAL: MAX260°C. 3S
- 操作力 OPERATION FORCE:350 $\pm$ 150gf
- 所有部件均使用环保材料 ALL MATERIALS ARE RoHS COMPLIANT

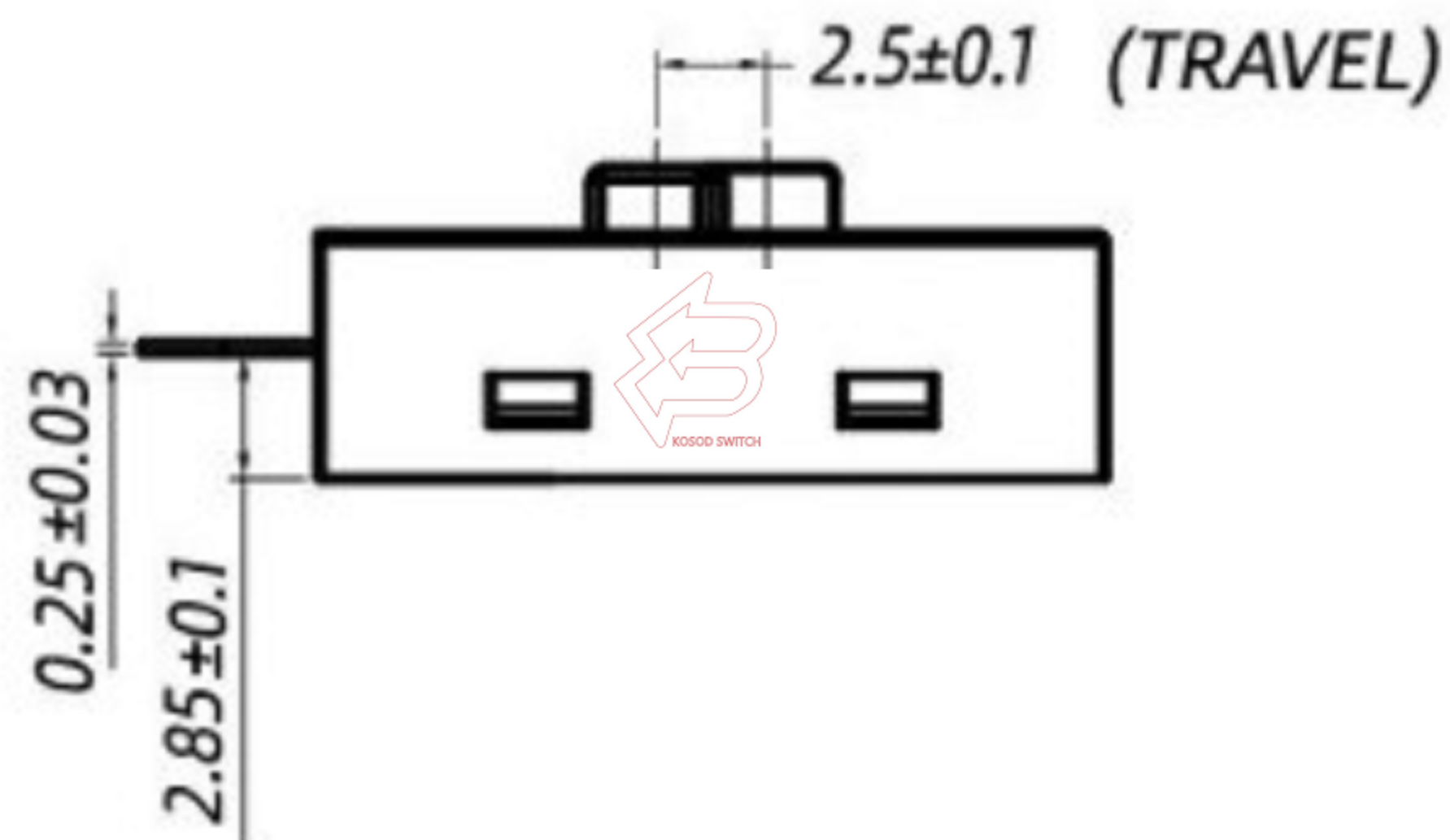

线路图  
CIRCUIT DIAGRAM

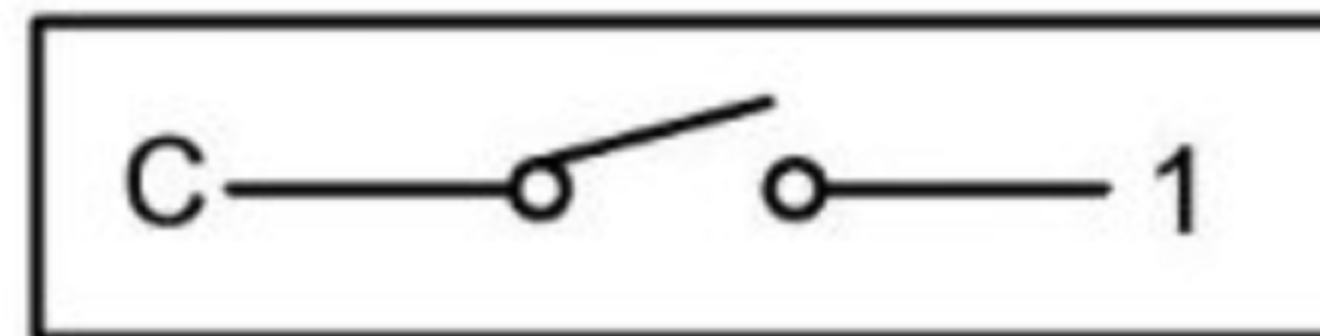

NO.	PARTS	MATERIALS	QTY	FINISH
5	CONTACT CLIP	PBS STRIP	1	Ag PLATED
4	TERMINAL	BRASS	3	Ag PLATED
3	BASE	PHENOLIC RESIN	1	NATURAL
2	FRAME	STEEL STRIP	1	Ni PLATED
1	KNOB	POM	1	BLACK



东莞市高迪电子有限公司  
DONG GUAN GAO DI ELECTRONICS CO., LTD

TOLERANCE UNLESS OTHERWISE STATED:  
Up to 5  $\pm$ 0.2  
Above 5 ~ 15  $\pm$ 0.3  
Above 15 ~ 30  $\pm$ 0.4  
Above 30 ~ 50  $\pm$ 0.5  
Angle  $\pm$ 0.3°

3RD. ANGEL'S

UNITS MM

DRAWN BY: Ming Ming Zou	DATE 11/19/14	MAT'L	TITLE SWITCH
CHECKED BY: Ning Ning Su	DATE 11/19/14	FINISH	MODLE SLIDE SWITCH
APPROVED BY: Jia Xiang	DATE 11/19/14	SCALE 1:1	DWG NO. GD-KND-1-DF002
SHEET NO. 1 of 1		PART NO.	SIZE A4 VER R2

ITEM NO.	DESCRIPTION	DRAWN	DATE
2	新增SPEC	Jack	111914
1	新增尺寸	Jack	061614