

SCHEMATIC

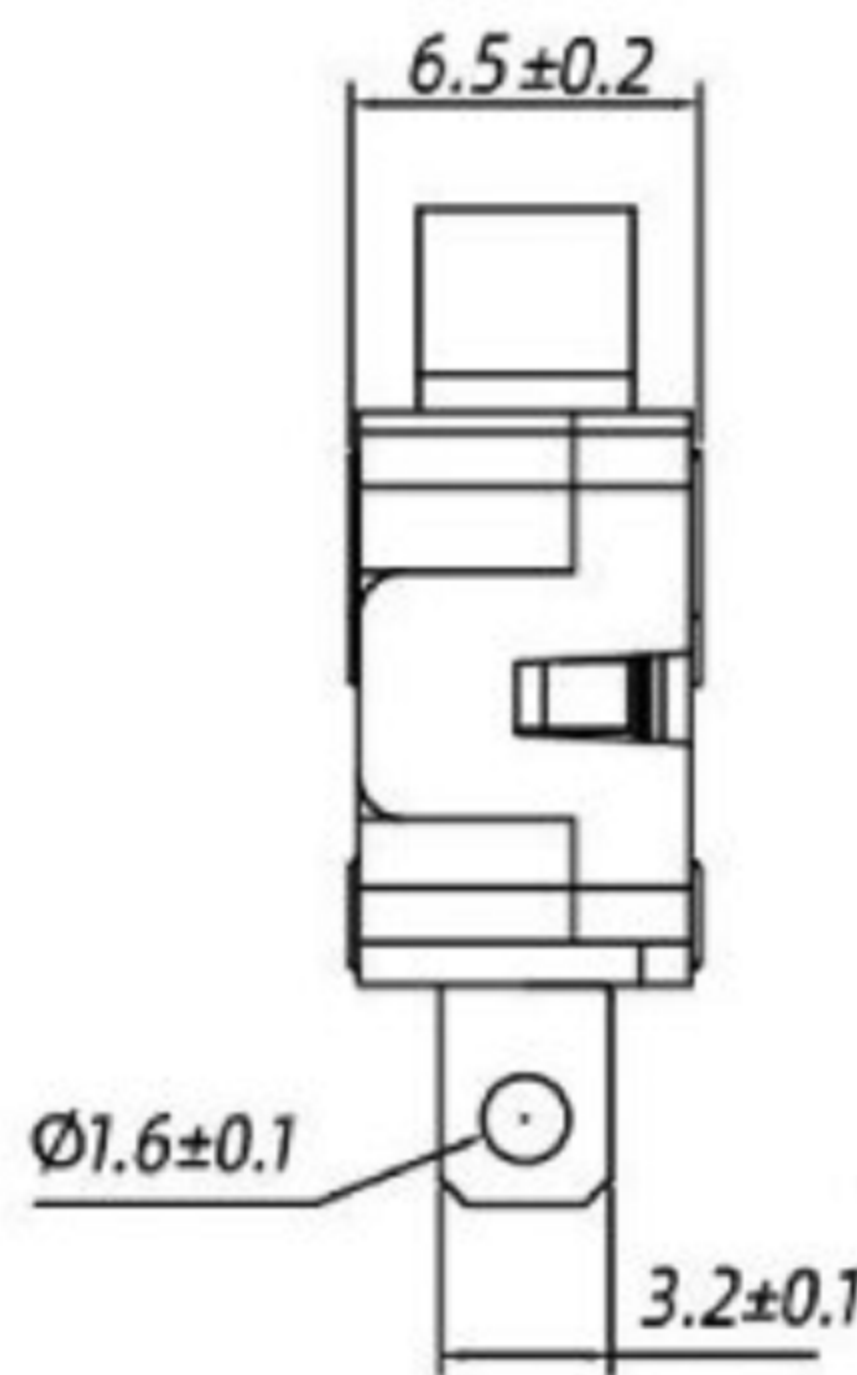
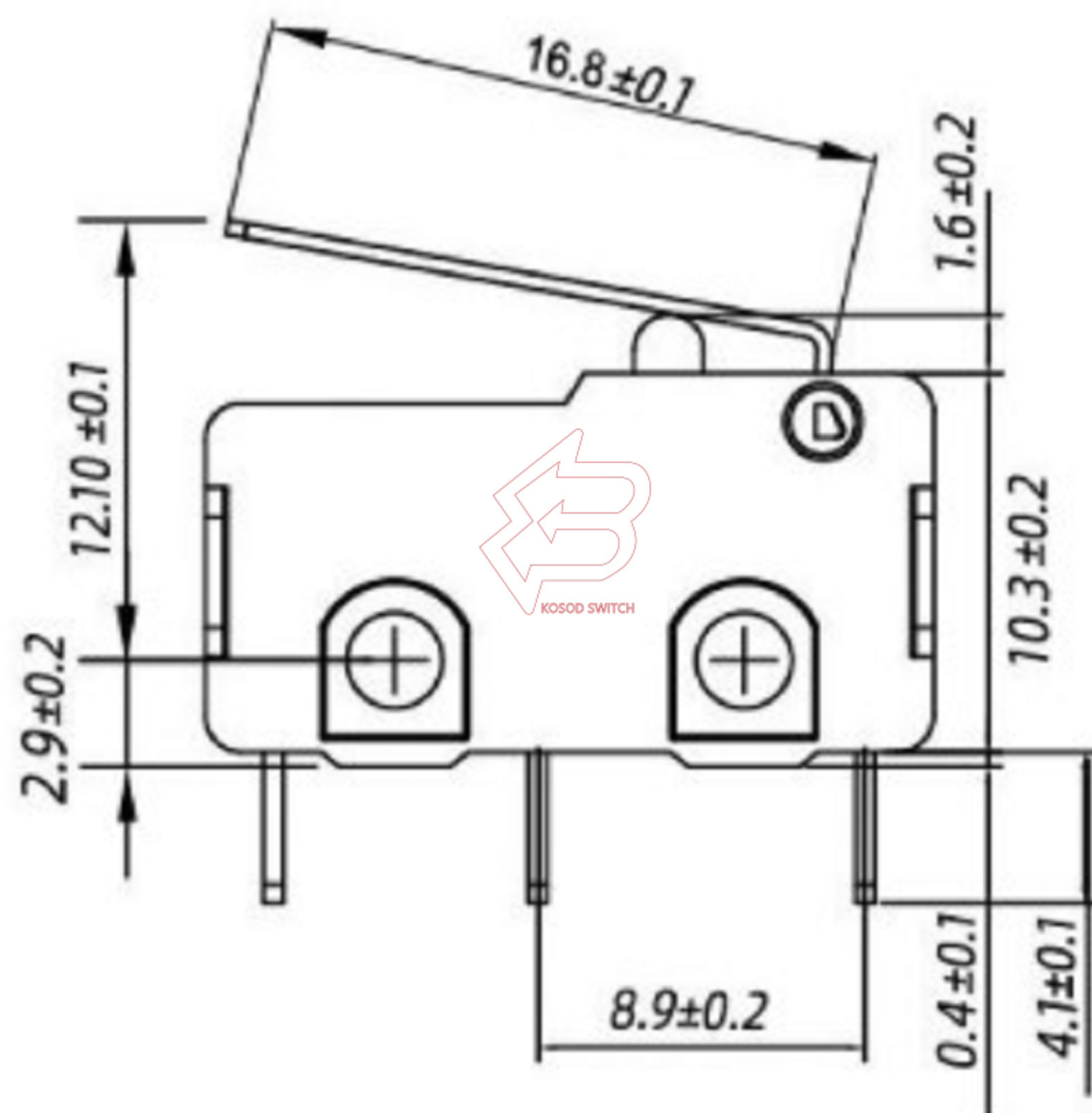
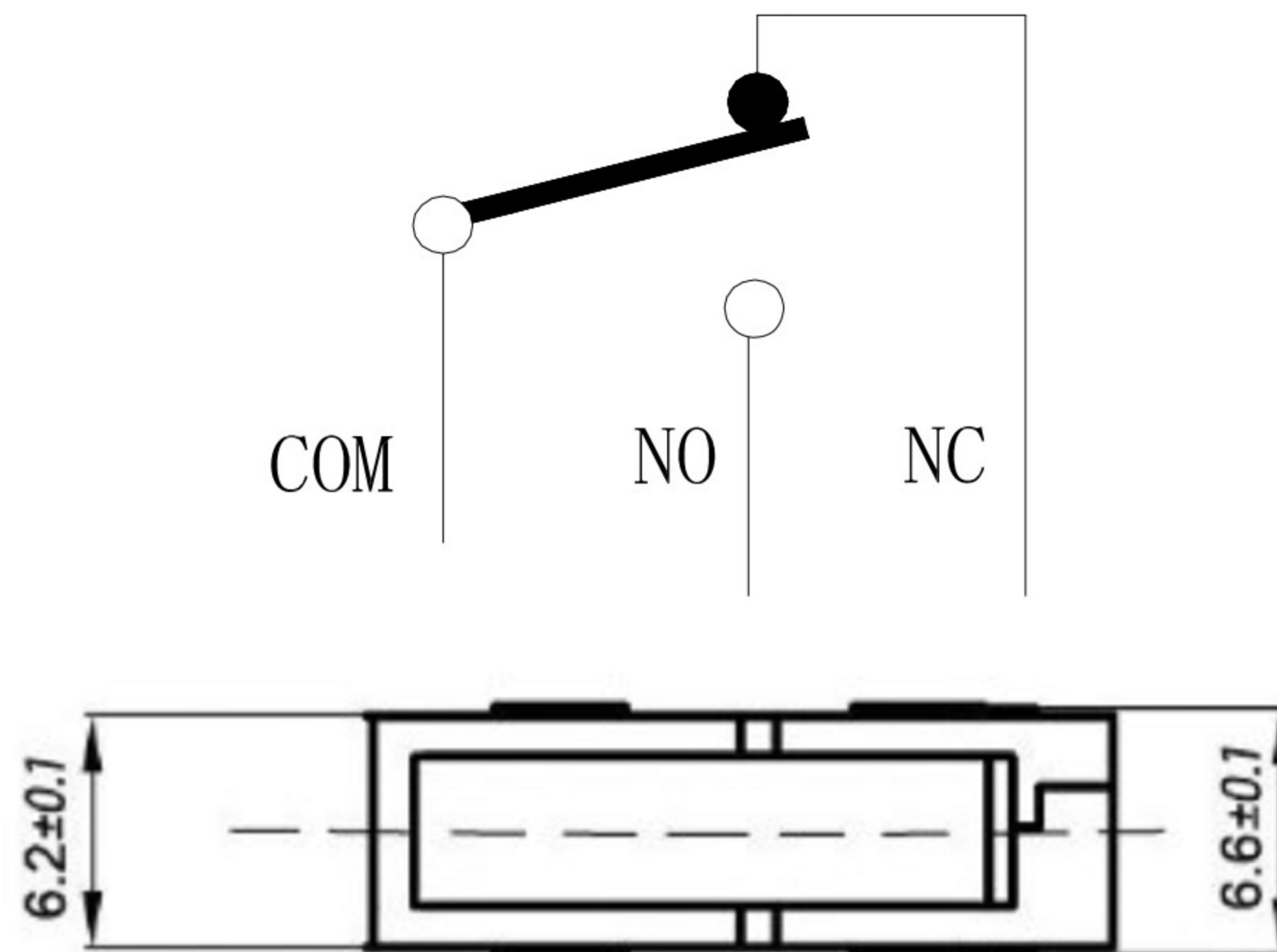
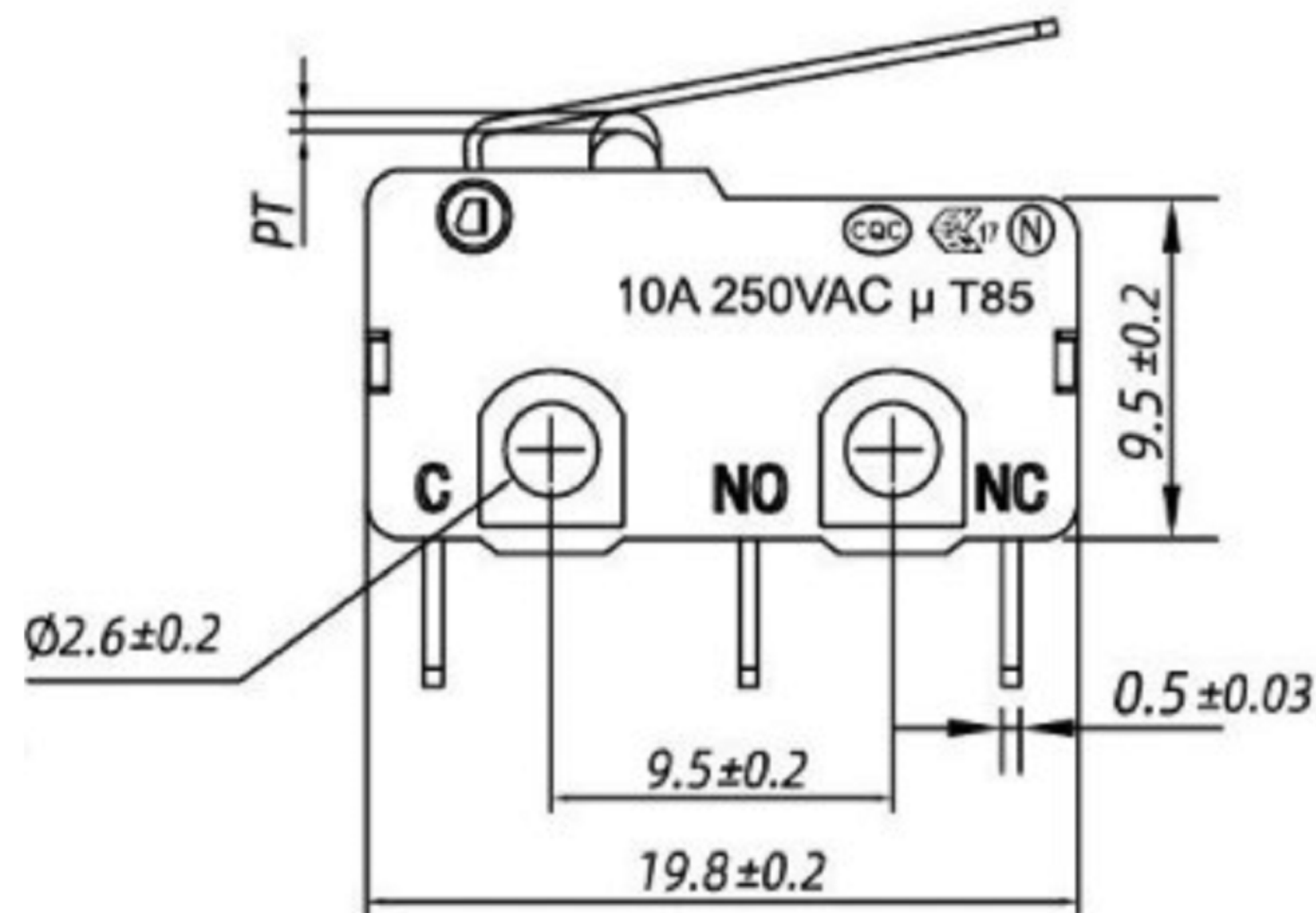

中微动开关

- 1.微动开关型号 MICRO SWITCH MODEL: LXW-3-6-3C-BS
- 2.焊线端子 SOLDER CONNECTOR TYPE;
单刀双掷 SINGLE POLE DOUBLE THROW
- 3.额定值 RATING: ▲ 10A 125/250VAC μ 25T85
5A 125/250VAC μ 25T85
▲ 10A 125/250VAC μ 25T85
▲ 10.1A 125/250VAC μ T125
- 4.接触电阻 CONTACT RESISTANCE: <math>< 50\text{m}\Omega</math> (INITIAL)
- 5.绝缘电阻 INSULATION RESISTANCE: $\geq 100\text{M}\Omega$ (DC500V/1MIN)
- 6.介电强度 DIELECTRIC STRENGTH: 1500V /5mA /1MIN
- 7.机械寿命 MECHANICAL LIFE: >100000 CYCLES
- 8.电气寿命 ELECTRICAL LIFE: >10000 CYCLES
- 9.端子手工焊接条件 SOLDER ABILITY OF TERMINAL: MAX260°C, 3S
- 10.操作力 OPERATION FORCE: 250±50gf
- 11.所有部件均使用环保材料 ALL MATERIALS ARE RoHS COMPLIANT

东莞市高迪电子有限公司
DONG GUAN GAO DI ELECTRONICS CO., LTD

TOLERANCE UNLESS OTHERWISE STATED:

Up to 5	±0.2
Above 5 ~ 15	±0.3
Above 15 ~ 30	±0.4
Above 30 ~ 50	±0.5
Angle	±0.3°

3RD. ANGEL'S UNITS MM

DRAWN BY:	DATE	MAT'L	TITLE	SWITCH
Ming Ming Zou	10/31/13			
CHECKED BY:	DATE	FINISH	MODLE	MICRO SWITCH
Ning Ning Su	10/31/13			
APPROVED BY:	DATE	SCALE	DWG NO.	GD-LXW-3-6-3C-BS
Jia Xiang	10/31/13	1:1		
SHEET NO.	1 of 1	PART NO.		
				SIZE A4
				VER R