

A

B

C

D

E

F

REV	DESCRIPTION	DESIGN	DATE
A0	Release	吴丹平	2013.08.05

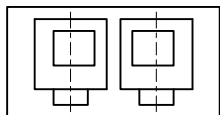

2.50

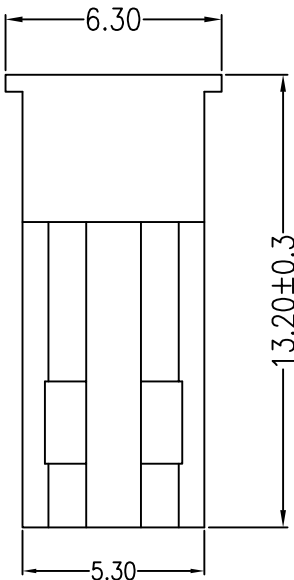

6.30

5.30

13.20±0.3

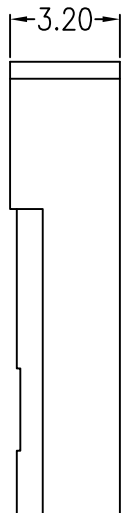

3.20

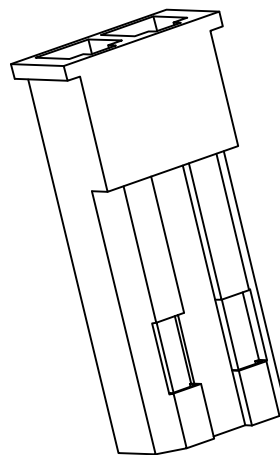

### 主要技术参数 Main Specifications

线 数 (Poles): 02  
 接触电阻 (Contact resistance):  $\leq 20\text{m}\Omega$   
 绝缘电阻 (Insulation resistance):  $\geq 1000\text{M}\Omega$   
 额定电压 (Rated voltage): 250V AC DC  
 额定电流 (Rated current): 3.0A AC DC  
 耐 电 压 (Withstand Voltage): 1000V AC/minute  
 温度范围 (Temperature Range):  $-25^{\circ}\text{C} \sim +85^{\circ}\text{C}$

### ORDER INFORMATION:

**C2502P-02-A5W-P**

PART No. \_\_\_\_\_  
 No. FOR CIRCUITS: \_\_\_\_\_  
 PACKAGING: P=PE  
 PLASTIC MATERIAL: A5W=PA66 (BEIGE)  
 A5R=PA66 (RED)

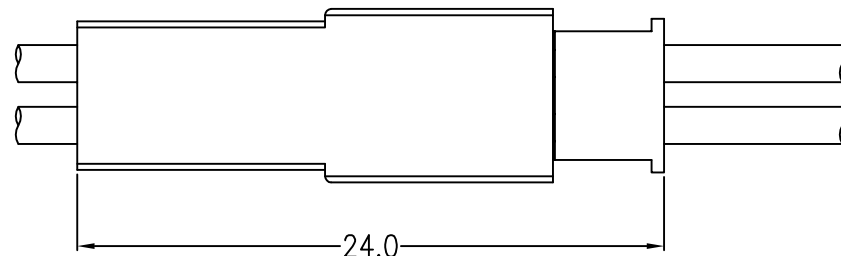

Assembly Layout

24.0

A

B

C

D

E

F

C				
B				
A	PEDESTAL	1 PCS	PA66	
ITEM	COMPONENT	Q'TY	MATERIAL	FINISH
<b>东莞市高迪电子有限公司</b> DONG GUAN GAO DI ELECTRONICS CO., LTD				TITLE:
X.±0.5	X.±5'	USE:	PART NO.:	
.X±0.3	.X±2'	APPD:	C2502P-02-A5W-P	
.XX±0.25	.XX±1'	CHKD:	DWG NO.:	
--	--	DR:	JKUN/GCCP-0600	
⊕	◁	UNITS: mm	SCALE	SHEET
			1 : 1	1 / 1

A

B

C

D

E

F

REV	ECN No.	DESCRIPTION	DESIGN	DATE
A0		Release	???	2018.01.22

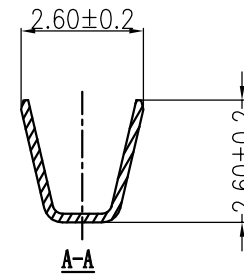
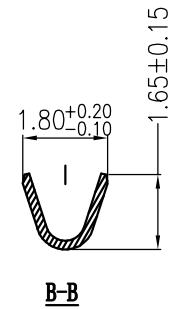
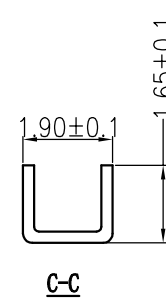
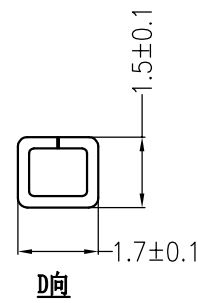
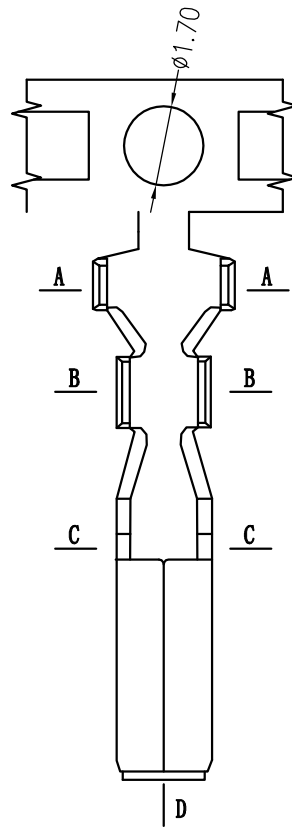
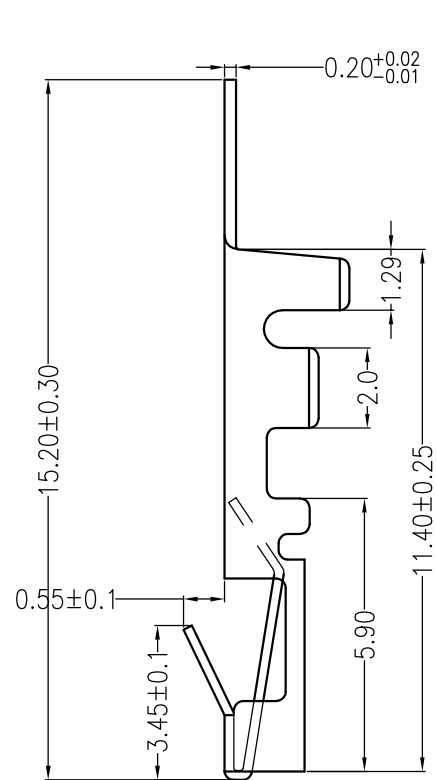

### Ordering Information & Specification:

Part No	Wire Range	Insulation O.D.	Material	Finish	Qty/Reel
C2502PT-PA	AWG #22~#28	1.0~1.80mm	Phosphor bronze	Sn-plated	9000 pcs

<b>東莞市高迪電子有限公司</b> DONG GUAN GAO DI ELECTRONICS CO., LTD			TITLE: C2502PT	
X.±0.5	X.±5'	USE:	CUSTOMER	
.X±0.3	.X±2'	APPD:	邵敬和	
.XX±0.25	.XX±1'	CHKD:	田峰	
---	---	DR:	蒋建银	
UNITS: mm		SCALE	SHEET	
		1 : 1	1 / 1	

A

B

C

D

E

F

1

2

3

4

5

1

2

3

4

5

REV	DESCRIPTION	DESIGN	DATE
A0	Release	吴丹平	2013.08.05

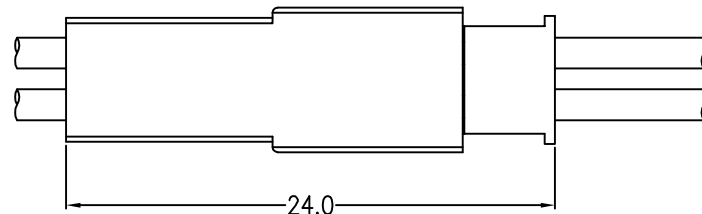
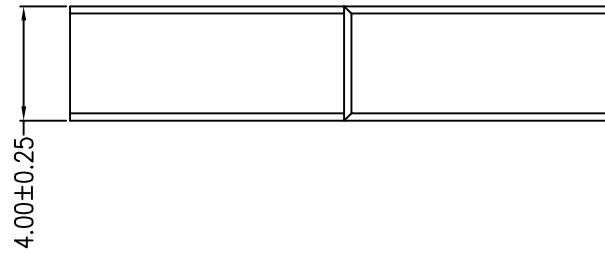
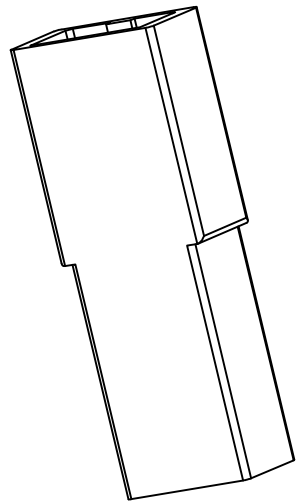
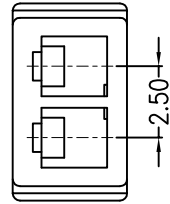

Assembly Layout

主要技术参数 Main Specifications

线 数 (Poles): 02  
 接触电阻 (Contact resistance):  $\leq 20m\Omega$   
 绝缘电阻 (Insulation resistance):  $\geq 1000M\Omega$   
 额定电压 (Rated voltage): 250V AC DC  
 额定电流 (Rated current): 3.0A AC DC  
 耐 电 压 (Withstand Voltage): 1000V AC/minute  
 温度范围 (Temperature Range):  $-25^{\circ}C \sim +85^{\circ}C$

ORDER INFORMATION:

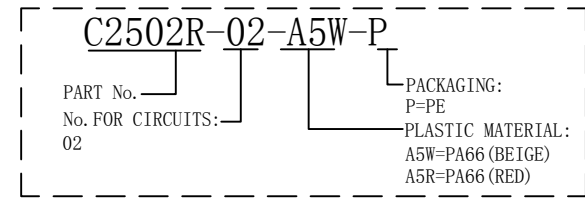

C				
B				
A	PEDESTAL	1 PCS	PA66	
ITEM	COMPONENT	Q'TY	MATERIAL	FINISH

**东莞市高迪电子有限公司**  
 DONG GUAN GAO DI ELECTRONICS CO., LTD

TITLE:

X.±0.5	X.±5'	USE:	CUSTOMEP	
.X±0.3	.X±2'	APPD:	邵敬和	
.XX±0.25	.XX±1'	CHKD:	田 峰	
--	--	DR:	吴丹平	
 UNITS: mm		SCALE	1 : 1	SHEET
				1 / 1

PART NO.: C2502R-02-A5W-P

DWG NO.: JKUN/GCCP-0599

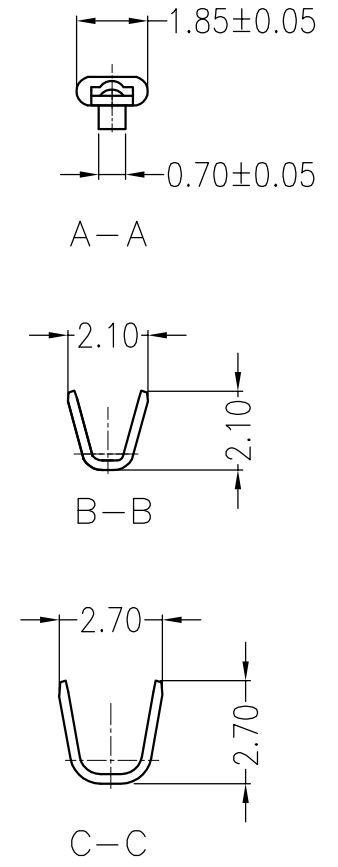
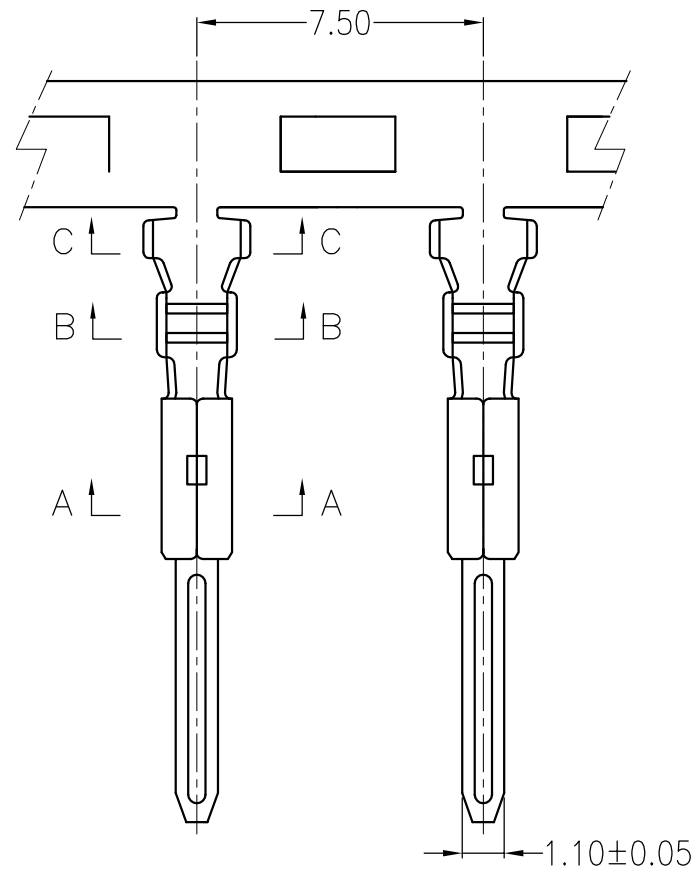
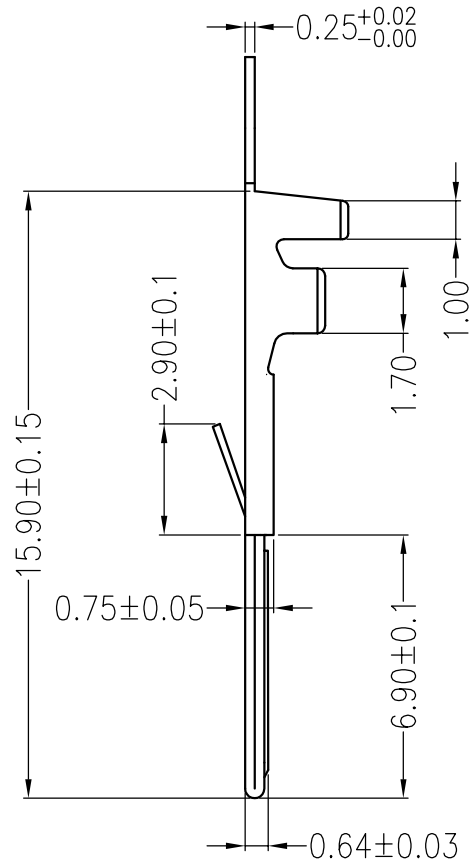

REV	ECN No.	DESCRIPTION	DESIGN	DATE
A0		Release	蒋建银	2018.01.20



Ordering Information & Specification:

Part No	Wire Range	Insulation O. D.	Material	Finish	Qty/Reel
C2501RT-PA	AWG #22~#28	1.0~1.80mm	Phosphor bronze	Sn-plated	10,000 pcs

 东莞市高迪电子有限公司  
DONG GUAN GAO DI ELECTRONICS CO., LTD

X±0.5	X±5'	USE: CUSTOMER
.X±0.3	.X±2'	
.XX±0.25	.XX±1'	APPD: 邵敬和
--	--	CHKD: 田峰
 	UNITS: mm	DR: 蒋建银

TITLE: C2501RT	
PART NO.: C2501RT-PA	
DWG NO.: JKUN-GCDZ-0029	
SCALE: 1 : 1	SHEET: 1 / 1