

REV	DESCRIPTION	DESIGN	DATE
A0	Release	吴丹平	2016.06.27

Circuits	Dimensions (mm)			Circuits	Dimensions (mm)		
	DIM. A	DIM. B	DIM. C		DIM. A	DIM. B	DIM. C
02	2.50	5.60	8.00	08	17.50	20.60	23.00
03	5.00	8.10	10.50	09	20.00	23.10	25.50
04	7.50	10.60	13.00	10	22.50	25.60	28.00
05	10.00	13.10	15.50	11	25.00	28.10	30.50
06	12.50	15.60	18.00	12	27.50	30.60	33.00
07	15.00	18.10	20.50				

**主要技术参数 Main Specifications**

线数 (Poles): 02 to 12P  
 接触电阻 (Contact resistance):  $\leq 20m\Omega$   
 绝缘电阻 (Insulation resistance):  $\geq 500M\Omega$   
 额定电压 (Rated voltage): 250 V AC DC  
 额定电流 (Rated current): 3.0A AC DC  
 耐电压 (Withstand Voltage): 1500V AC/minute  
 温度范围 (Temperature Range):  $-25^{\circ}C \sim +85^{\circ}C$

**ORDER INFORMATION:**

**C2501R-\*\*-\*\*\*-P**

PART No.		PACKAGING:
No. OF CIRCUITS:		P=PE
02~12		PLASTIC MATERIAL:
		A5W=PA66 (White)
		A5K=PA66 (Black)

C				
B				
A	PEDESTAL	1 PCS	PA66	
ITEM	COMPONENT	Q'TY	MATERIAL	FINISH

 <b>东莞市高迪电子有限公司</b> DONG GUAN GAO DI ELECTRONICS CO., LTD			TITLE:
X.±0.5	X.±5'	USE:	PART NO.:
.X±0.3	.X±2'	CUSTOMEP	C2501R-**-***-P
.XX±0.25	.XX±1'	APPD:	DWG NO.:
--	--	邵敬和	GCCP-0597
		CHKD:	SCALE
UNITS: mm	DR:	田峰	1 : 1
		吴丹平	SHEET
			1 / 1

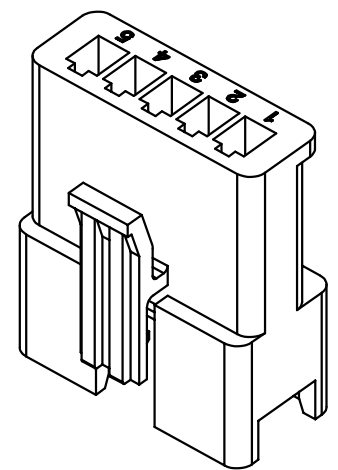
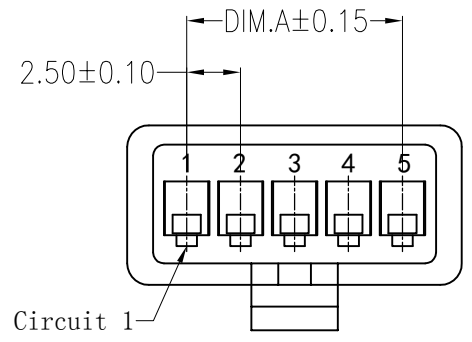
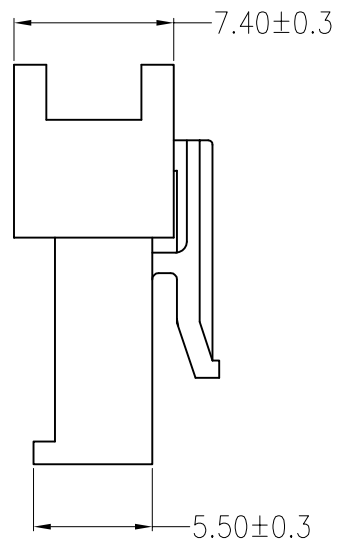
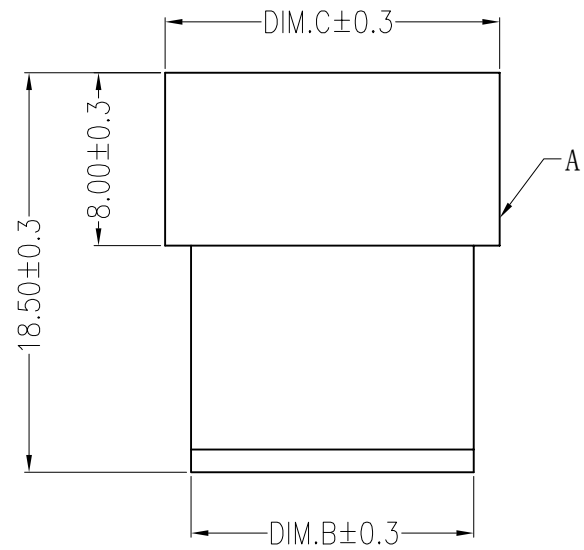

REV	ECN No.	DESCRIPTION	DESIGN	DATE
A0		Release	蒋建银	2018.01.20

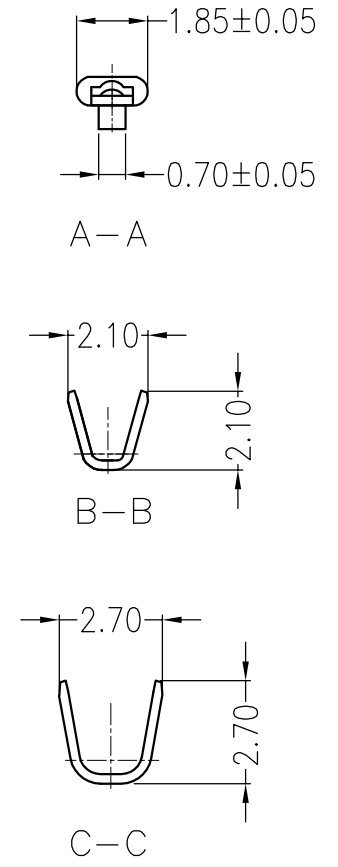
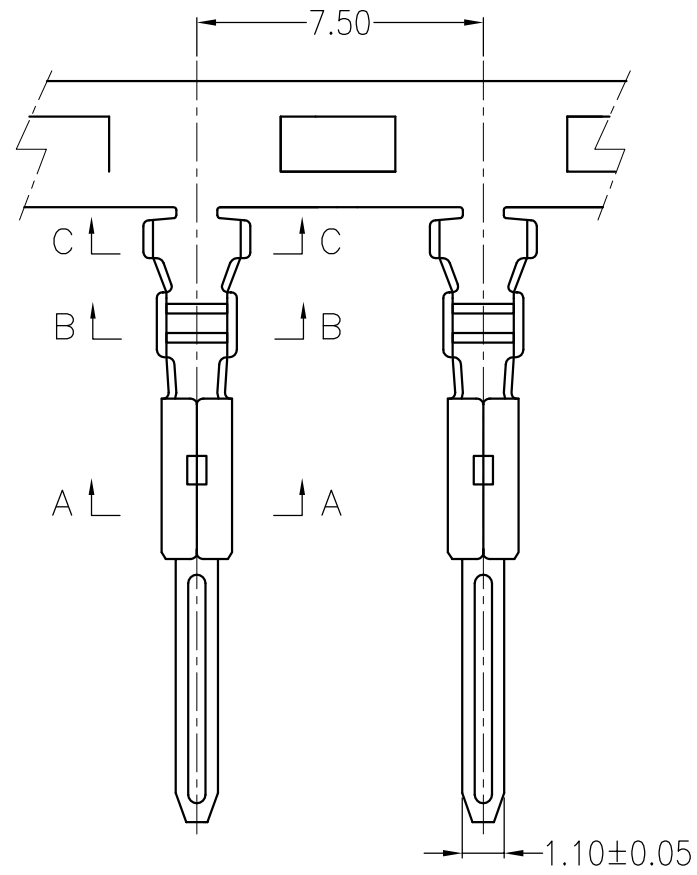
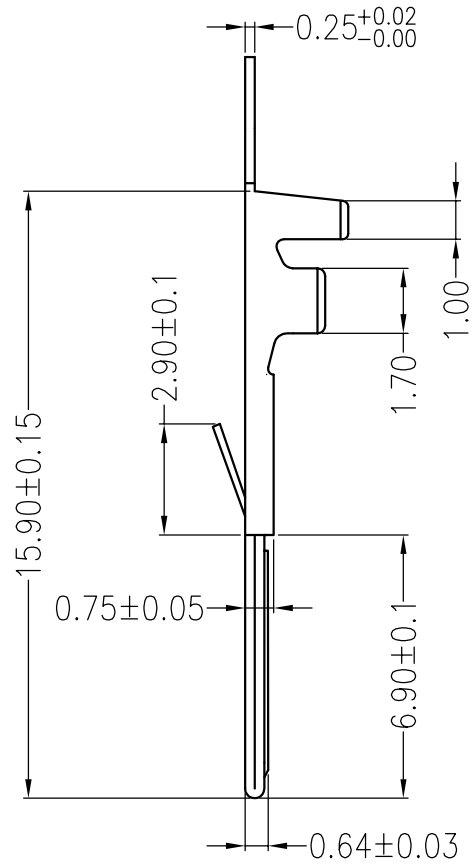

Ordering Information & Specification:

Part No	Wire Range	Insulation O. D.	Material	Finish	Qty/Reel
C2501RT-PA	AWG #22~#28	1.0~1.80mm	Phosphor bronze	Sn-plated	10,000 pcs

<b>東莞市高迪電子有限公司</b> DONG GUAN GAO DI ELECTRONICS CO., LTD			TITLE: C2501RT	
X.±0.5	X.±5'	USE: CUSTOMER	PART NO.: C2501RT-PA	
.X±0.3	.X±2'		DWG NO.: GCDZ-0029	
.XX±0.25	.XX±1'	APPD: 邵敬和	SCALE 1 : 1	
--	--	CHKD: 田峰	SHEET 1 / 1	
⊕	◁	UNITS: mm	DR: 蒋建银	