

A | B | C | D | E | F

Circuits	Dimensions (mm)		
	A	B	C
02	2.50	6.10	7.50
03	5.00	8.60	10.00
04	7.50	11.10	12.50
05	10.00	13.60	15.00
06	12.50	16.10	17.50
07	15.00	18.60	20.00
08	17.50	21.10	22.50
09	20.00	23.60	25.00
10	22.50	26.10	27.50
11	25.00	28.60	30.00
12	27.50	31.10	32.50
13	30.00	33.60	35.00
14	32.50	36.10	37.50
15	35.00	38.60	40.00
16	37.50	41.10	42.50

REV	DESCRIPTION	DESIGN	DATE
A	NEW RELEASE	Lingqing	2021/06/02

**Specifications:**  
 Contact resistance:  $\leq 20m\Omega$   
 Insulation resistance:  $\geq 1000M\Omega$   
 Rated voltage: 250V AC DC  
 Rated current: 3.0A AC DC  
 Withstand voltage: 1000V AC/minute  
 Temperature range:  $-25^{\circ}C \sim +105^{\circ}C$   
 Housing: LCP UL94V-0, Natural  
 Cap: LCP UL94V-0, Natural  
 Contacts: Brass/Sn-plated

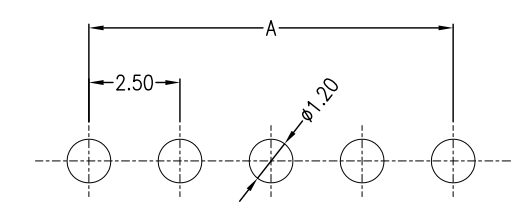
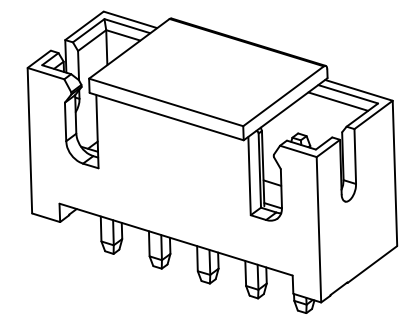
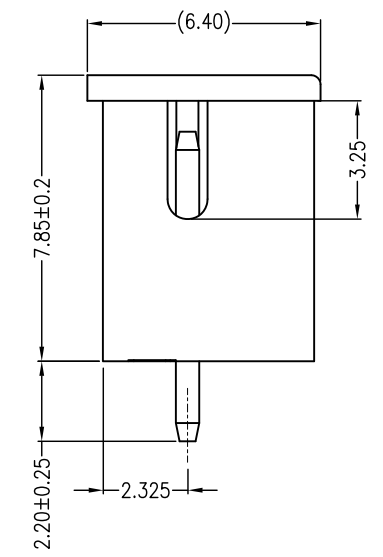
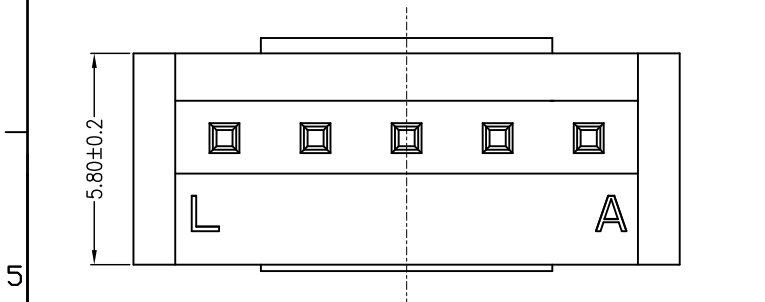
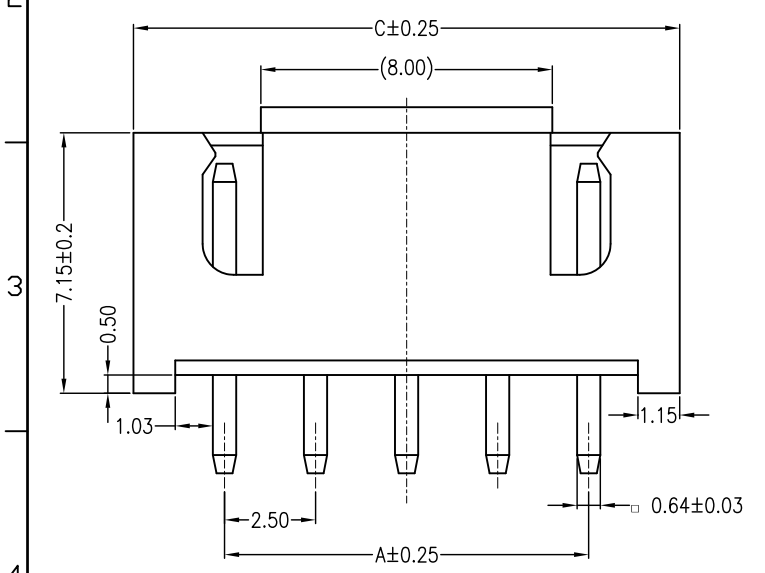
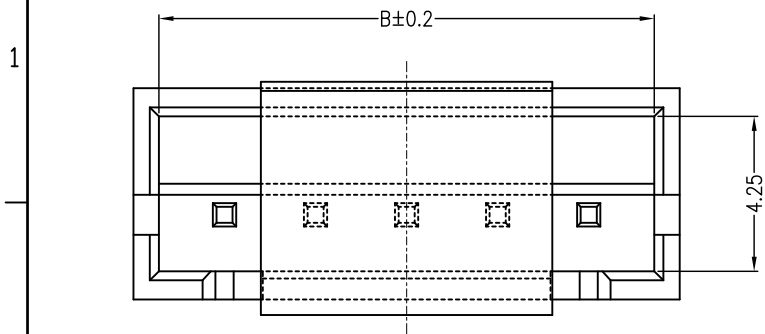

RECOMMENDED PCB LAYOUT(TOP VIEW)  
 TOLERANCE:  $\pm 0.05mm$

ORDER INFORMATION:

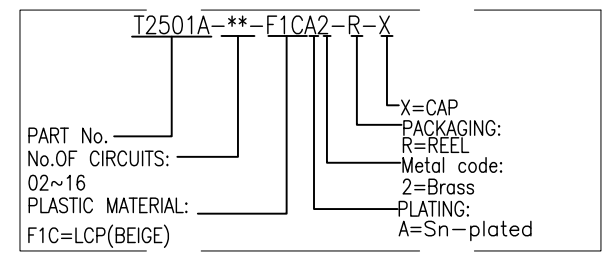

东莞市高迪电子有限公司 DONG GUAN GAO DI ELECTRONICS CO., LTD		TITLE:	
		2.50mm pitch 180°Wafe DIP type	
GENERAL TOLERANCE		USE:	PART NO.:
X. $\pm 0.50$	X. $\pm 5'$	CUSTOMER	T2501A-**-F1CA2-R-X
X.X $\pm 0.30$	X.X $\pm 2'$	APPD: Shaojinghe	DWG NO.:
X.XX $\pm 0.20$	X.XX $\pm 1'$	CHKD: Fangsongle	GCKH-0930
		UNITS: mm	SCALE
		DR: Zenglingqing	1 : 1
			SHEET
			1 / 1

A | B | C | D | E | F

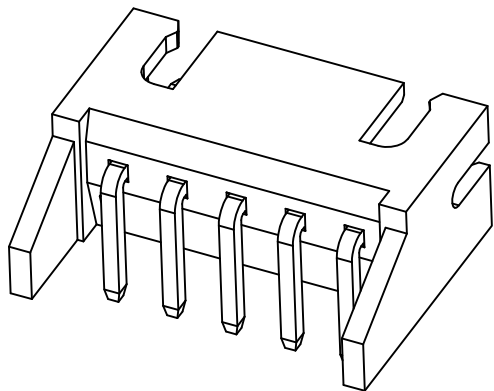
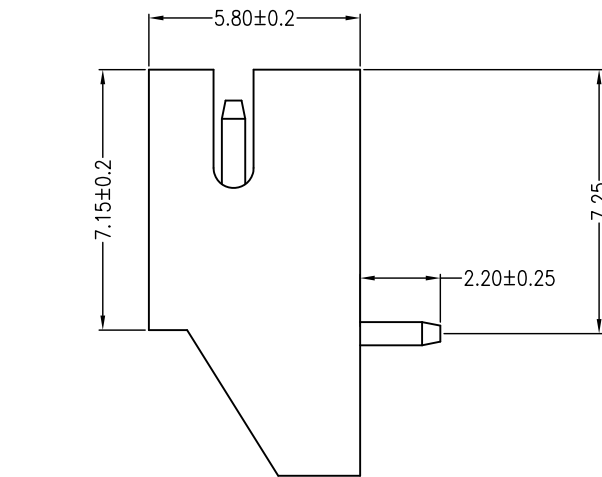
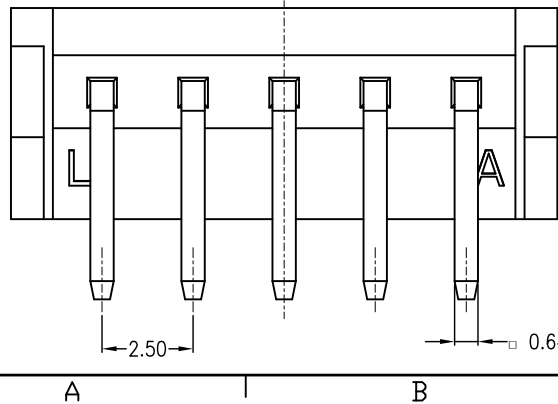
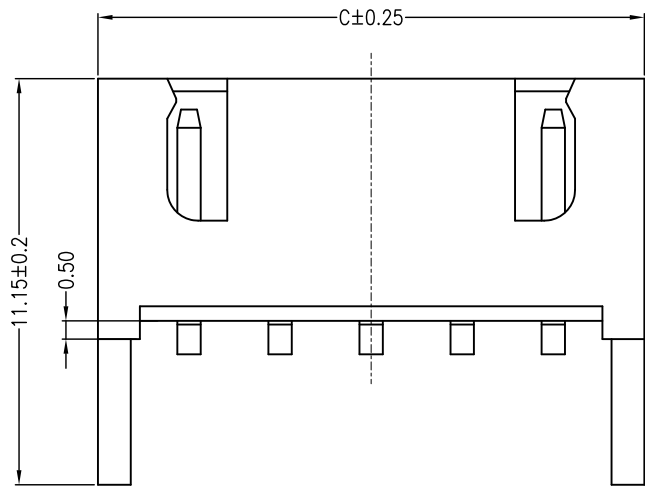
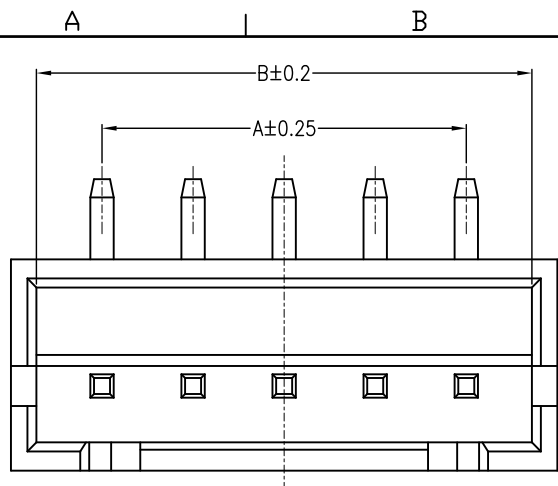

Circuits	Dimensions (mm)		
	A	B	C
02	2.50	6.10	7.50
03	5.00	8.60	10.00
04	7.50	11.10	12.50
05	10.00	13.60	15.00
06	12.50	16.10	17.50
07	15.00	18.60	20.00
08	17.50	21.10	22.50
09	20.00	23.60	25.00
10	22.50	26.10	27.50
11	25.00	28.60	30.00
12	27.50	31.10	32.50
13	30.00	33.60	35.00
14	32.50	36.10	37.50
15	35.00	38.60	40.00
16	37.50	41.10	42.50

REV	DESCRIPTION	DESIGN	DATE
A	NEW RELEASE	Lingqing	2021/06/02

**Specifications:**  
 Contact resistance:  $\leq 20m\Omega$   
 Insulation resistance:  $\geq 1000M\Omega$   
 Rated voltage: 250V AC DC  
 Rated current: 3.0A AC DC  
 Withstand voltage: 1000V AC/minute  
 Temperature range:  $-25^{\circ}C \sim +105^{\circ}C$   
 Housing: LCP UL94V-0, Natural  
 Contacts: Brass/Sn-plated

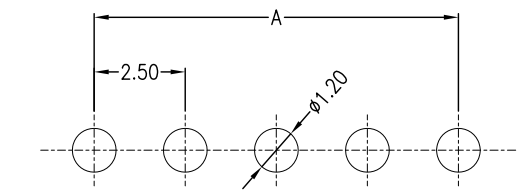

RECOMMENDED PCB LAYOUT(TOP VIEW)  
 TOLERANCE:  $\pm 0.05mm$

ORDER INFORMATION:  
**T2501AWD-\*\*-F1CA2-R**

PART No. \_\_\_\_\_  
 No.OF CIRCUITS: \_\_\_\_\_  
 02~16  
 PLASTIC MATERIAL: \_\_\_\_\_  
 F1C=LCP(BEIGE)

PACKAGING:  
 R=REEL  
 Metal code:  
 2=Brass  
 PLATING:  
 A=Sn-plated

<b>東莞市高迪電子有限公司</b> DONG GUAN GAO DI ELECTRONICS CO., LTD		TITLE: 2.5mm pitch 90°Wafe DIP type	
		PART NO.: T2501AWD-**-F1CA2-R	
GENERAL TOLERANCE		USE: CUSTOMER	
X. $\pm 0.50$	X. $\pm 5^{\circ}$	APPD: Shaojinghe	
X.X $\pm 0.30$	X.X $\pm 2^{\circ}$	CHKD: Fangsongle	
X.XX $\pm 0.20$	X.XX $\pm 1^{\circ}$	DR: Zenglingqing	
 UNITS: mm		SCALE 1 : 1	SHEET 1 / 1

REV	ECN No.	DESCRIPTION	DESIGN	DATE
A		Release	程永海	2022.06.02

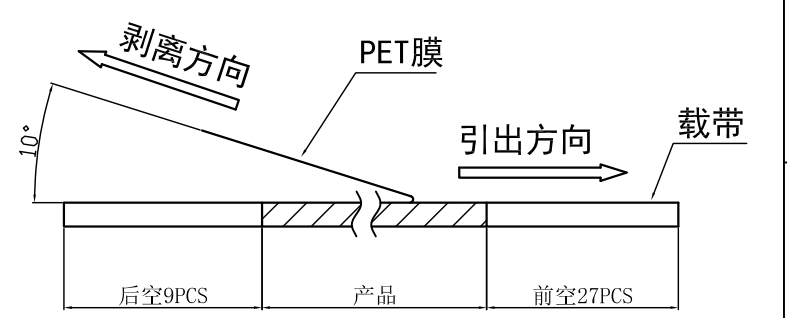
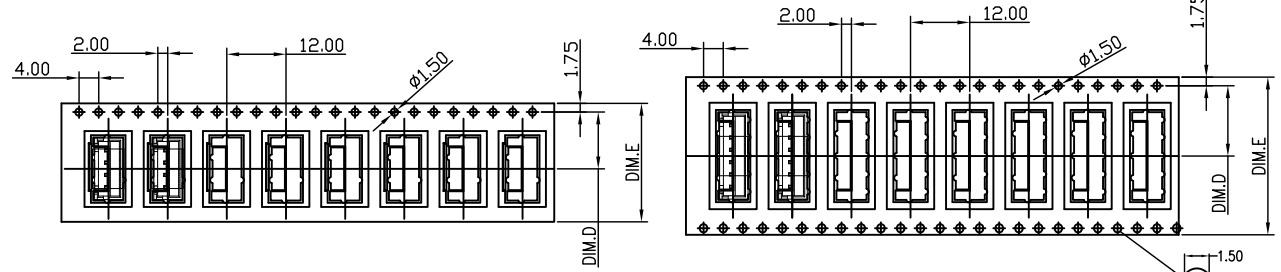

02~05 CONTACTS

06~07 CONTACTS

(PET膜剥离示意图)

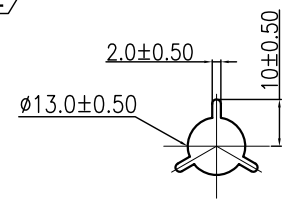
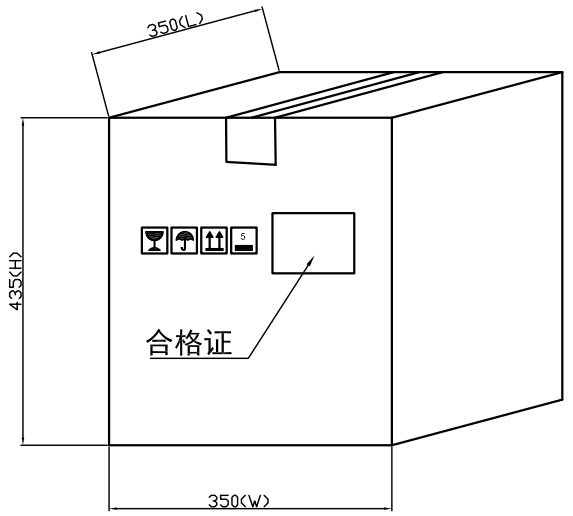
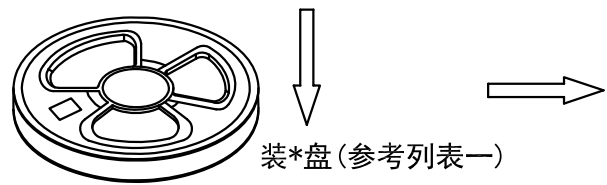
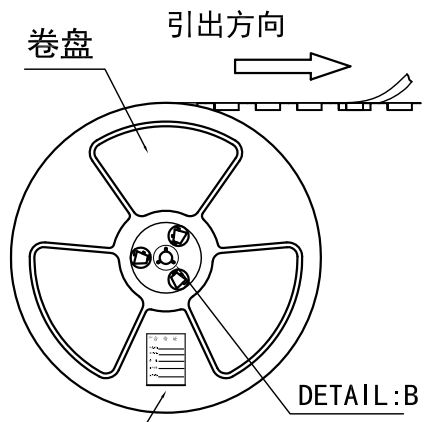

列表一

Circuits	DIM. D	DIM. E	Q'ty/Reel	Packing (Reel/Caton)
02 PIN	7.5	16	500PCS	20/Reel
03-05 PIN	11.5	24	500PCS	15/Reel
06-07 PIN	14.25	32	500PCS	11/Reel

包装说明:

- 把成品包入卷盘中, 每盘装500PCS, 卷盘上贴上合格证, 将装好产品的卷盘放进外箱中, 外箱内先套一个大PE袋, 外箱上贴贴上合格证.
- 所有材料有害物控制需符合RoHS标准.

**东莞市高迪电子有限公司**  
DONG GUAN GAO DI ELECTRONICS CO., LTD

X.± 0.5	X.±'	USE: MANUFACTURE
.X± 0.3	.X±'	APPD: 邵敬和
.XX±0.25	.XX±'	CHKD: 蒋建银
--	--	DR: 程永海
UNITS: mm		

TITLE: T2501A
PART NO.: T2501A包装规范
DWG NO.: GCKH-0930
SCALE: 1 : 1
SHEET: 1 / 1