

REV	DESCRIPTION	DESIGN	DATE
A	NEW RELEASE	Lingqing	2020/03/27

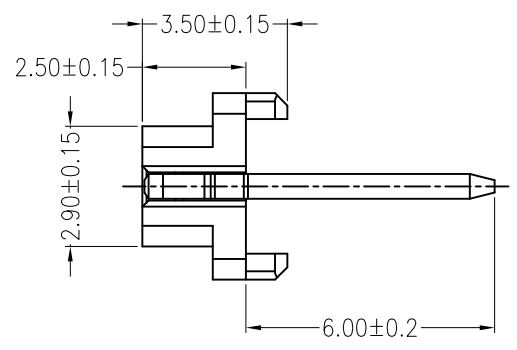

Specifications:

- Contact resistance: $\leq 20\text{m}\Omega$
- Insulation resistance: $\geq 1000\text{M}\Omega$
- Rated voltage: 230V AC DC
- Rated current: 1.0A AC DC
- Withstand Voltage: 1500V AC/minute
- Temperature Range: $-40^{\circ}\text{C} \sim +110^{\circ}\text{C}$
- Housing: LCP UL94V-0, BEIGE
- Contacts: Brass / Sn-plated

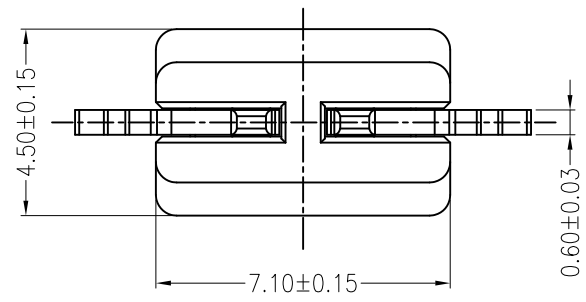
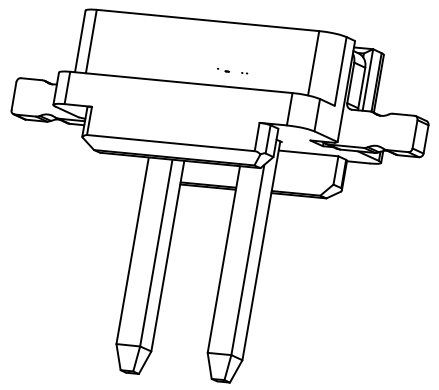
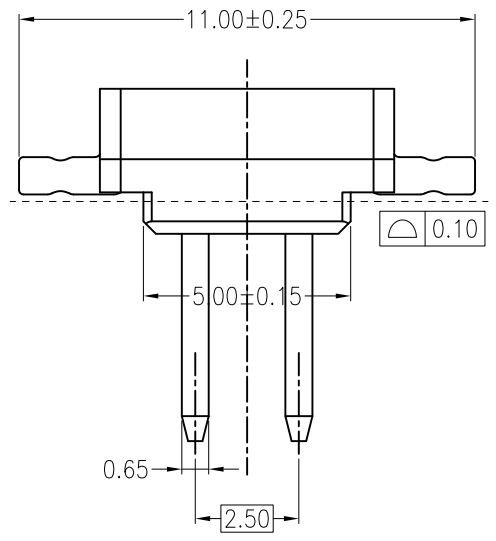

ORDER INFORMATION:

L2504AFV-02-F8MA3-*

PART No.	PACKAGING:
No.OF CIRCUITS:	P=PE
02	R=REEL
PLASTIC MATERIAL:	Metal code:
F8M=LCP(BEIGE)	3=Brass
	PLATING:
	A=Sn-plated

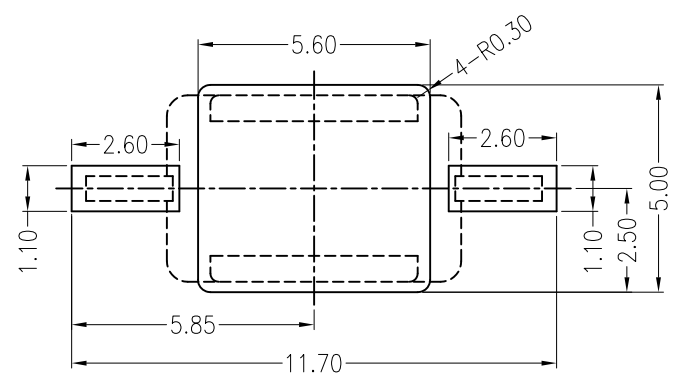

Board Layout
General Tolerance: ± 0.05

東莞市高迪電子有限公司 DONG GUAN GAO DI ELECTRONICS CO., LTD		TITLE: 2.5mmPITCH 180°WAFER SMT TYPE	
		PART NO.: L2504AFV-02-F8MA3-*	
GENERAL TOLERANCE		USE: CUSTOMER	
X. ± 0.50	X. $\pm 5^{\circ}$	APPD: Liuzhengling	
X.X ± 0.30	X.X $\pm 2^{\circ}$	CHKD: Steven	
X.XX ± 0.20	X.XX $\pm 1^{\circ}$	DR: Zenglingqing	
UNITS: mm		SCALE 1 : 1	SHEET 1 / 1