

REV	ECN No.	DESCRIPTION	DESIGN	DATE
A0		Release	-	2018.07.02

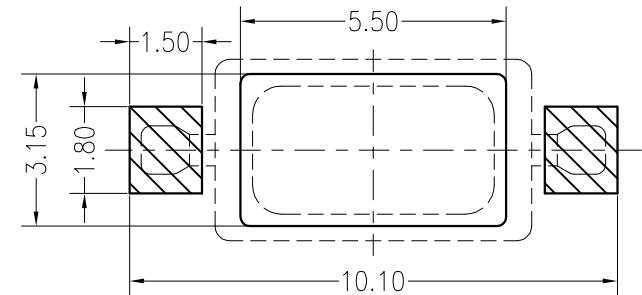

Board Layout  
General Tolerance: ±0.05

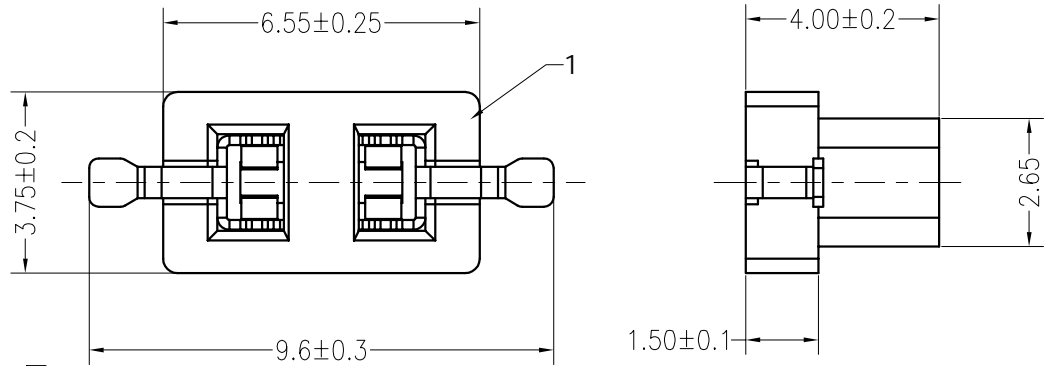
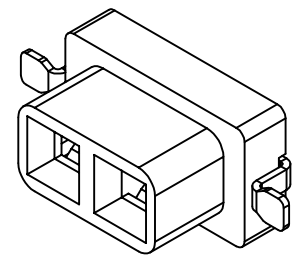
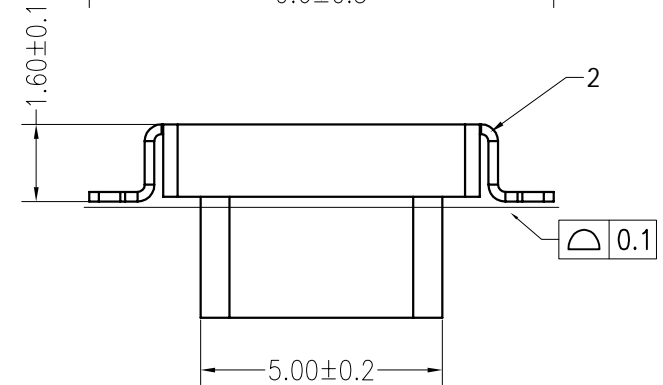

主要技术参数 Main Specifications

- 线数 (Poles): 02
- 接触电阻 (Contact resistance): ≤30mΩ
- 绝缘电阻 (Insulation resistance): ≥1000MΩ
- 额定电压 (Rated voltage): 250V AC DC
- 额定电流 (Rated current): 1.0A AC DC
- 耐电压 (Withstand Voltage): 500V AC/minute
- 温度范围 (Temperature Range): -40°C ~ +110°C

ORDER INFORMATION:

**L2501AFV-02-F6MB1-R**

PART No. \_\_\_\_\_  
 No. FOR CIRCUITS: 02 \_\_\_\_\_  
 PLASTIC MATERIAL: \_\_\_\_\_  
 F6M=LCP(BEIGE) PLATING: B=MATTE Sn \_\_\_\_\_

PACKAGING:  
 R=REEL P=PE  
 Metal code:  
 1=Phosphor bronze

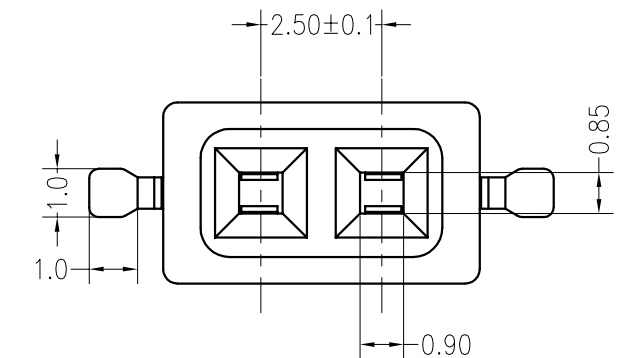

C				
B	CONTACT	2 PCS	Phosphor bronze	TIN-plated
A	pedestal	1 PCS	LCP	UL 94V-0, COLOR:BEIGE
ITEM	COMPONENT	Q'TY	MATERIAL	FINISH

**东莞市高迪电子有限公司**  
**DONG GUAN GAO DI ELECTRONICS CO., LTD**

TITLE: L2501AFV-02

X.±0.5	X.±5'	USE: CUSTOMER	PART NO.: L2501AFV-02-F6MB1-R
.X±0.3	.X±2'		
.XX±0.25	.XX±1'	APPD: 邵敬和	DWG NO.: GCCP-1177
--	--	CHKD: 田峰	SCALE: 1:1
⊕	∠	UNITS: mm	DR: 蒋建银

SHEET 1 / 1