

REV	DESCRIPTION	DESIGN	DATE
A0	NEW RELEASE	Lingqing	2020/07/11

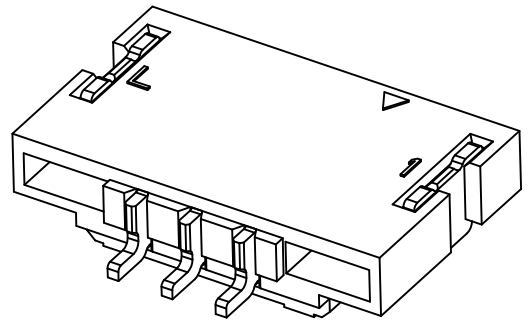

**Specifications:**

- Contact resistance:  $\leq 20m\Omega$
- Insulation resistance:  $\geq 100M\Omega$
- Rated voltage: 50V AC DC
- Rated current: 1.0A AC DC
- Withstand Voltage: 500V AC/minute
- Temperature Range:  $-25^{\circ}C \sim +85^{\circ}C$
- Housing: PA6T UL94V-0, Natural (Beige)
- Contacts: Phosphor bronze / Matte Sn
- Solder Tabs: Phosphor bronze / Matte Sn

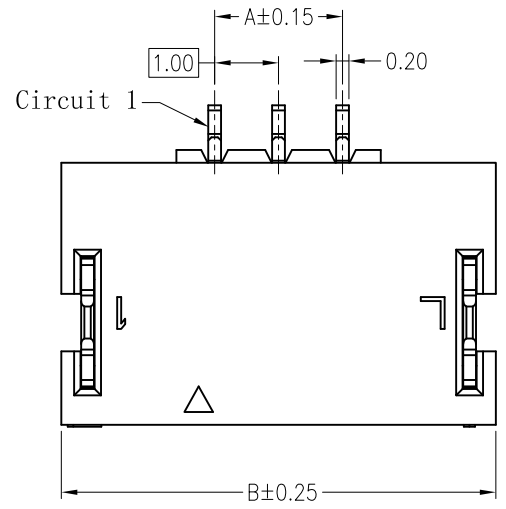
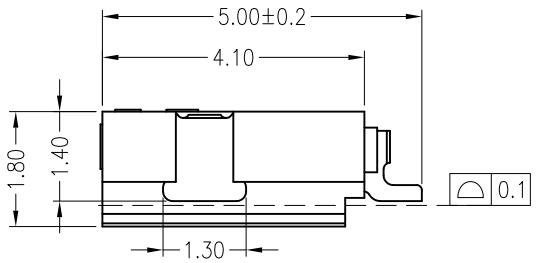
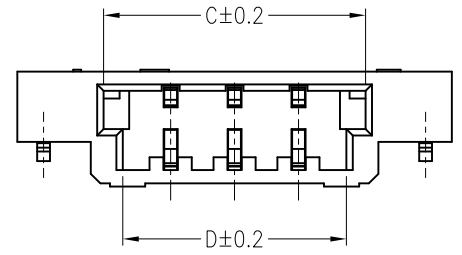

Circuits	Dimensions (mm)				Circuits	Dimensions (mm)			
	A	B	C	D		A	B	C	D
02	1.00	5.80	3.10	2.50	*17	16.00	20.80	18.10	17.50
03	2.00	6.80	4.10	3.50	*18	17.00	21.80	19.10	18.50
04	3.00	7.80	5.10	4.50	*19	18.00	22.80	20.10	19.50
05	4.00	8.80	6.10	5.50	*20	19.00	23.80	21.10	20.50
06	5.00	9.80	7.10	6.50	*21	20.00	24.80	22.10	21.50
07	6.00	10.80	8.10	7.50	*22	21.00	25.80	23.10	22.50
08	7.00	11.80	9.10	8.50	*23	22.00	26.80	24.10	23.50
*09	8.00	12.80	10.10	9.50	*24	23.00	27.80	25.10	24.50
*10	9.00	13.80	11.10	10.50	*25	24.00	28.80	26.10	25.50
*11	10.00	14.80	12.10	11.50	*26	25.00	29.80	27.10	26.50
*12	11.00	15.80	13.10	12.50	*27	26.00	30.80	28.10	27.50
*13	12.00	16.80	14.10	13.50	*28	27.00	31.80	29.10	28.50
*14	13.00	17.80	15.10	14.50	*29	28.00	32.80	30.10	29.50
*15	14.00	18.80	16.10	15.50	*30	29.00	33.80	31.10	30.50
*16	15.00	19.80	17.10	16.50					

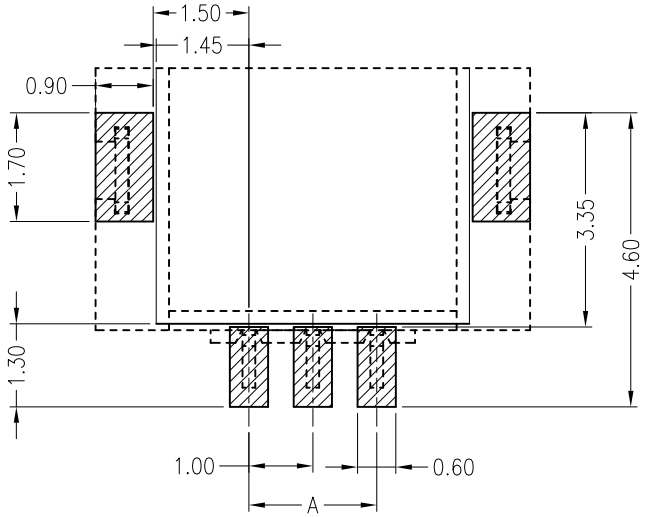

**ORDER INFORMATION:**

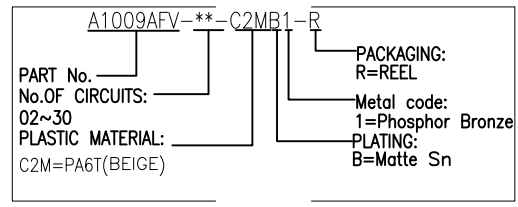

**東莞市高迪電子有限公司**  
DONG GUAN GAO DI ELECTRONICS CO., LTD

TITLE:  
1.0 Pitch Wafer 90° SMT

GENERAL TOLERANCE		USE:
X. $\pm 0.50$	X. $\pm 5'$	CUSTOMER
X.X $\pm 0.30$	X.X $\pm 2'$	APPD: WangFeng
X.XX $\pm 0.20$	X.XX $\pm 1'$	CHKD: Shaojinghe
		DR: Zenglingqing

PART NO.:	
A1009AFV-**-C2MB1-R	
DWG NO.:	
GCKH-0879	
SCALE	SHEET
1 : 1	1 / 1

A B C D E F

1

2

3

4

5

1

2

3

4

REV	DESCRIPTION	DESIGN	DATE
A0	NEW RELEASE	Lingqing	2020/07/11

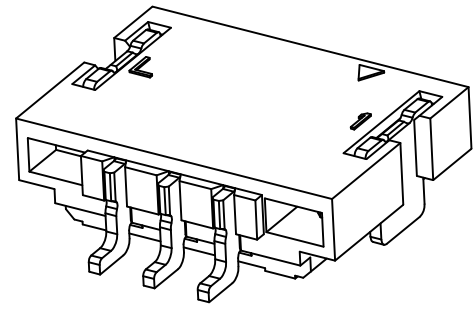
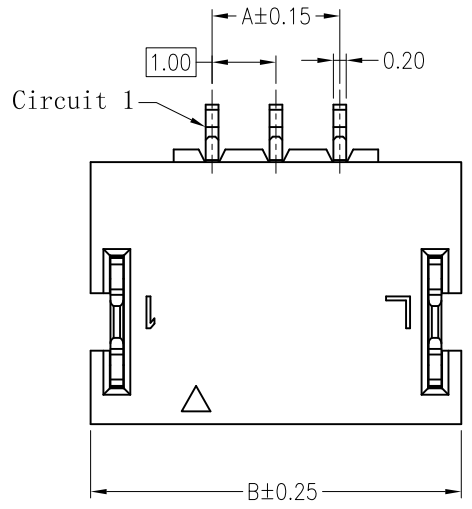

**Specifications:**

- Contact resistance:  $\leq 20m\Omega$
- Insulation resistance:  $\geq 100M\Omega$
- Rated voltage: 50V AC DC
- Rated current: 1.0A AC DC
- Withstand Voltage: 500V AC/minute
- Temperature Range:  $-25^{\circ}C \sim +85^{\circ}C$
- Housing: PA6T UL94V-0, Natural (Beige)
- Contacts: Phosphor bronze / Matte Sn
- Solder Tabs: Phosphor bronze / Matte Sn

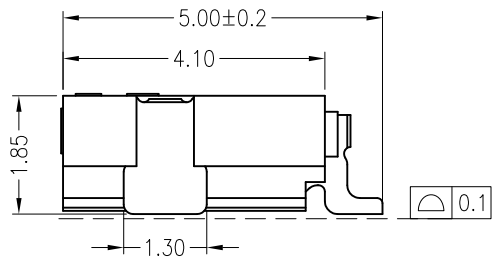
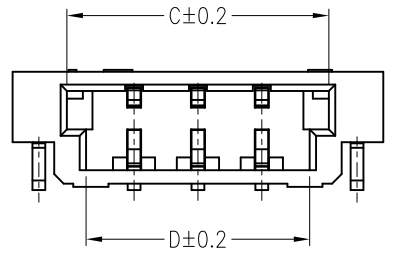

Circuits	Dimensions (mm)				Circuits	Dimensions (mm)			
	A	B	C	D		A	B	C	D
02	1.00	4.80	3.10	2.50	*17	16.00	19.80	18.10	17.50
03	2.00	5.80	4.10	3.50	*18	17.00	20.80	19.10	18.50
04	3.00	6.80	5.10	4.50	*19	18.00	21.80	20.10	19.50
05	4.00	7.80	6.10	5.50	*20	19.00	22.80	21.10	20.50
06	5.00	8.80	7.10	6.50	*21	20.00	23.80	22.10	21.50
07	6.00	9.80	8.10	7.50	*22	21.00	24.80	23.10	22.50
08	7.00	10.80	9.10	8.50	*23	22.00	25.80	24.10	23.50
*09	8.00	11.80	10.10	9.50	*24	23.00	26.80	25.10	24.50
*10	9.00	12.80	11.10	10.50	*25	24.00	27.80	26.10	25.50
*11	10.00	13.80	12.10	11.50	*26	25.00	28.80	27.10	26.50
*12	11.00	14.80	13.10	12.50	*27	26.00	29.80	28.10	27.50
*13	12.00	15.80	14.10	13.50	*28	27.00	30.80	29.10	28.50
*14	13.00	16.80	15.10	14.50	*29	28.00	31.80	30.10	29.50
*15	14.00	17.80	16.10	15.50	*30	29.00	32.80	31.10	30.50
*16	15.00	18.80	17.10	16.50					

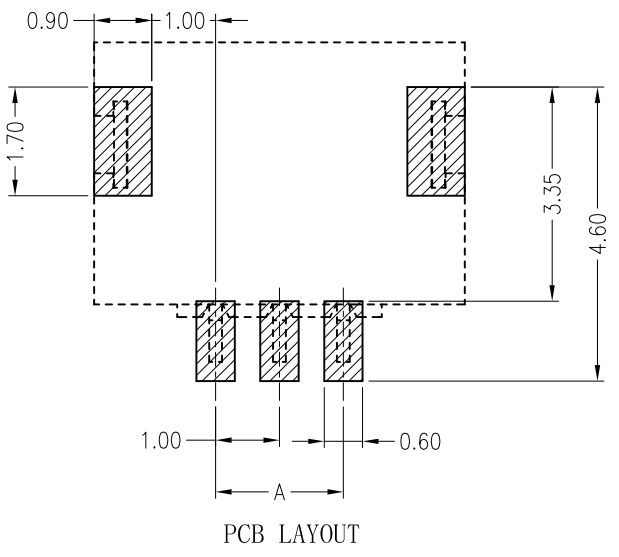

**ORDER INFORMATION:**

**A1009AWR-\*\*-C2MB1-R**  
 PART No. \_\_\_\_\_  
 No. OF CIRCUITS: \_\_\_\_\_  
 PLASTIC MATERIAL: \_\_\_\_\_  
 C2M=PA6T(BEIGE)  
 PACKAGING: R=REEL  
 Metal code: 1=Phosphor Bronze  
 PLATING: B=Matte Sn

<b>東莞市高迪電子有限公司</b> DONG GUAN GAO DI ELECTRONICS CO., LTD		TITLE: 1.0 Pitch Wafer 90° SMT	
		PART NO.: A1009AWR-**-C2MB1-R	
GENERAL TOLERANCE X. $\pm 0.50$ X. $\pm 5'$ X.X $\pm 0.30$ X.X $\pm 2'$ X.XX $\pm 0.20$ X.XX $\pm 1'$		USE: CUSTOMER APPD: WangFeng CHKD: Shaojinghe	
UNITS: mm 		DR: Zenglingqing SCALE: 1 : 1 SHEET: 1 / 1	

REV	ECN No.	DESCRIPTION	DESIGN	DATE
A		Release	蒋建银	2020.11.17

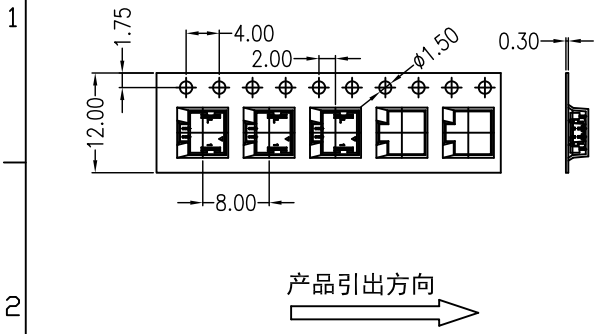

产品引出方向  
02 CONTACTS

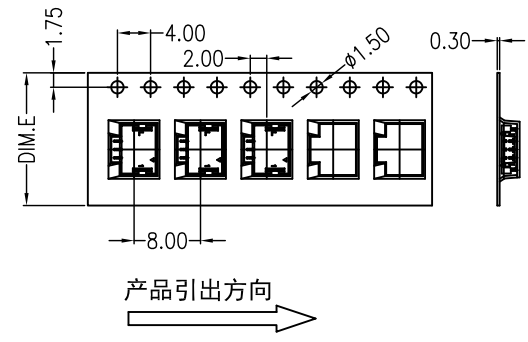

产品引出方向  
03~12 CONTACTS

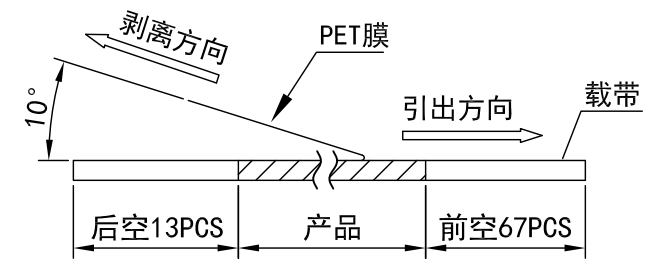

(PET膜剥离示意图)

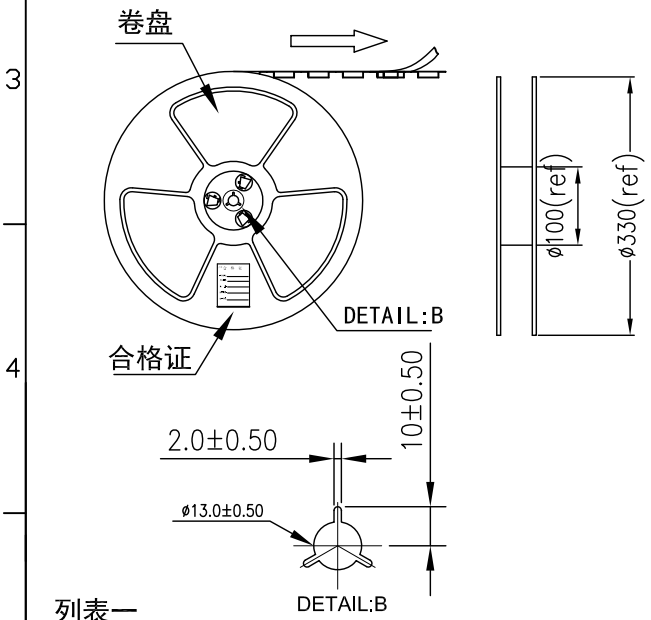

列表一

Circuits	DIM. D	DIM. E	Q'ty/Reel	Packing (Reel/Caton)
02PIN	-	12	4000PCS	25/Reel
03~06PIN	-	16	4000PCS	20/Reel
10~12PIN	-	24	4000PCS	15/Reel

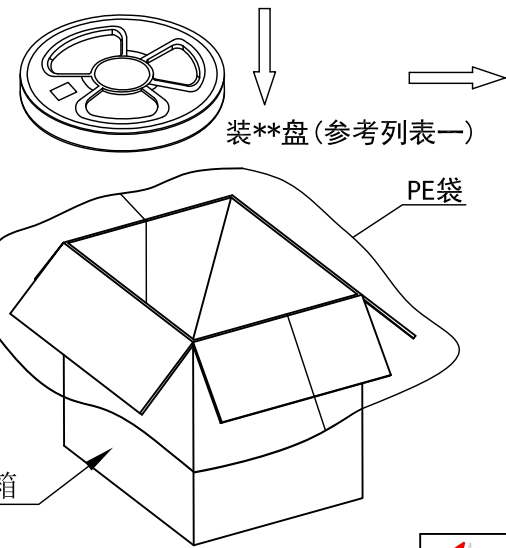

包装说明:

- 把成品包入卷盘中, 每盘装4000PCS, 卷盘上贴上合格证, 将装好产品的卷盘放进外箱中, 外箱内先套一个大PE袋, 外箱上贴贴上合格证.
- 所有材料有害物控制需符合RoHS标准.

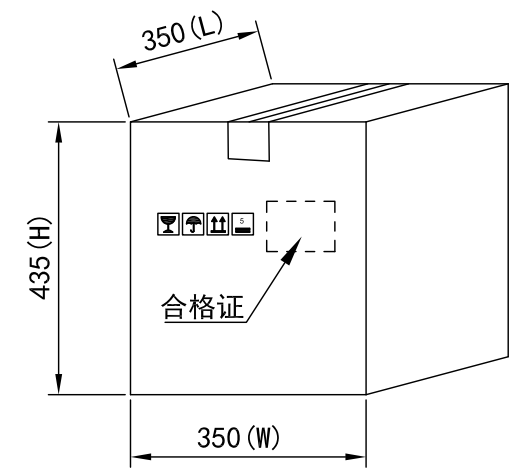

**东莞市高迪电子有限公司**  
DONG GUAN GAO DI ELECTRONICS CO., LTD

X.± 0.5	X.±'	USE: CUSTOMER
.X± 0.3	.X±'	APPD: 王锋
.XX±0.25	.XX±'	CHKD: 曾令青
--	--	DR: 蒋建银
UNITS: mm		

TITLE:	
PART NO.: A1009AWR-** 卷装规范	
DWG NO.: GCBZ-0866	
SCALE 1 : 1	SHEET 1 / 1