

PCB LAYOUT(Tolerance:±0.05)

REV	DESCRIPTION	DESIGN	DATE
A0	NEW RELEASE	Steven	2019/05/09

Specifications:
 Poles: 02 to 20
 Contact resistance: ≤20mΩ
 Insulation resistance: ≥100MΩ
 Rated voltage: 125V AC DC
 Rated current: 1.0A AC DC
 Withstand Voltage: 500V AC/minute
 Temperature Range: -25°C ~ +85°C
 Housing: PA6T UL94V-0, Natural
 Contacts: PhosphorBronze/Matte Sn-plated
 Solder Tabs: Brass/Matte Sn-plated

ORDER INFORMATION:
A1004AWR--C1MB1-R**

PART No.	PACKAGING: R=REEL
No.OF CIRCUITS: 02-20	Metl code: 1=PhosphorBronze
PLASTIC MATERIAL: C1M=PA6T	PLATING: B=Matte Sn

孔位	尺寸	A	B	C	孔位	尺寸	A	B	C
2P	1.00	2.50	3.50	12P	11.00	12.5	13.5		
3P	2.00	3.50	4.50	*13P	12.00	13.5	14.5		
4P	3.00	4.50	5.50	*14P	13.00	14.5	15.5		
5P	4.00	5.50	6.50	*15P	14.00	15.5	16.5		
6P	5.00	6.50	7.50	*16P	15.00	16.5	17.5		
7P	6.00	7.50	8.50	*17P	16.00	17.5	18.5		
8P	7.00	8.50	9.50	*18P	17.00	18.5	19.5		
9P	8.00	9.50	10.5	*19P	18.00	19.5	20.5		
10P	9.00	10.50	11.5	*20P	19.00	20.5	21.5		
*11P	10.00	11.50	12.5						

東莞市高迪電子有限公司 DONG GUAN GAO DI ELECTRONICS CO., LTD		TITLE: 1.0 Pitch Wafer 90° SMT	
		PART NO.: A1004AWR-**-C1MB1-R	
GENERAL TOLERANCE		USE: CUSTOMER	
X. ±0.50	X. ±5°	APPD: Wangliang	
X.X ±0.30	X.X ±2°	CHKD: Liuzhengling	
X.XX ±0.20	X.XX ±1°	DR: Steven	
UNITS: mm		SCALE 1 : 1	
		SHEET 1 / 1	

REV	DESCRIPTION	DESIGN	DATE
A0	NEW RELEASE	Steven	2019/05/09

线数 (N)	尺寸 mm	
	A	B
2	1.00	2.40
3	2.00	3.40
4	3.00	4.40
5	4.00	5.40
6	5.00	6.40
7	6.00	7.40
8	7.00	8.40
9	8.00	9.40
10	9.00	10.40
11	10.00	11.40
12	11.00	12.40
13	12.00	13.40
14	13.00	14.40
15	14.00	15.40

Specifications:
Poles: 02 to 15
Contact resistance: $\leq 20m\Omega$
Insulation resistance: $\geq 100M\Omega$
Rated voltage: 125V AC DC
Rated current: 1.0A AC DC
Withstand Voltage: 500V AC/minute
Temperature Range: $-25^{\circ}C \sim +85^{\circ}C$
Housing: PA66 UL94V-0, Natural

ORDER INFORMATION:

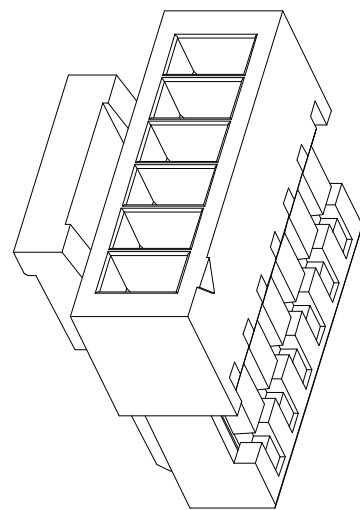
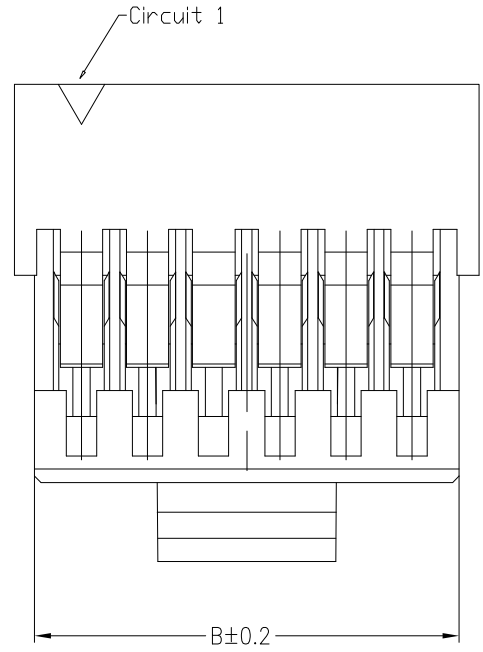
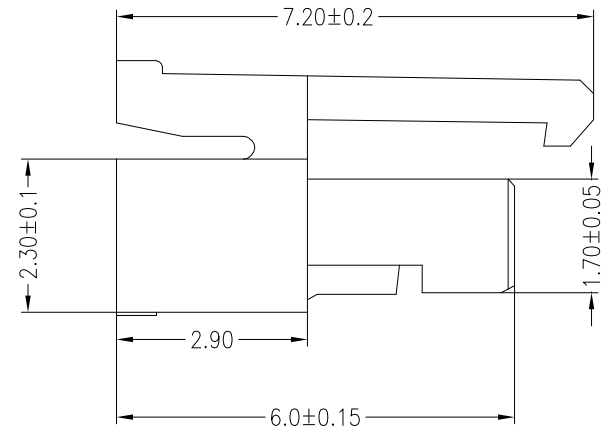
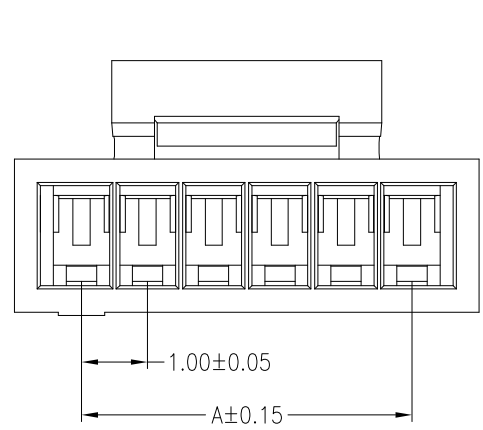
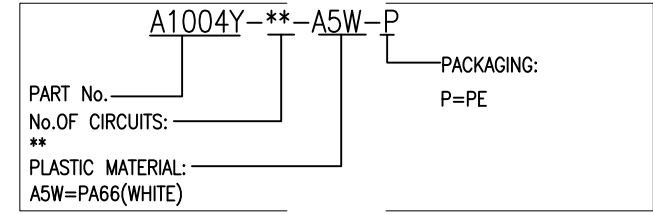

東莞市高迪電子有限公司 DONG GUAN GAO DI ELECTRONICS CO., LTD		TITLE: 1.0 Pitch HOUSING	
GENERAL TOLERANCE		USE: CUSTOMER	PART NO.:
X. ±0.50	X. ±5'	APPD: Wangliang	A1004Y-**-A5W-P
X.X ±0.30	X.X ±2'	CHKD: Zenglingqing	DWG NO.:
X.XX ±0.20	X.XX ±1'	DR: Steven	GCCP-0829
UNITS: mm		SCALE 1 : 1	SHEET 1 / 1

REV	ECN No.	DESCRIPTION	DESIGN	DATE
A		Release	蒋建银	2019.05.22

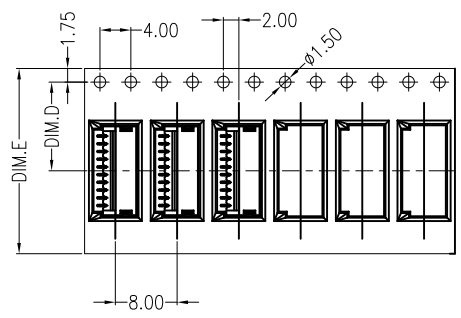

2~15 CONTACTS

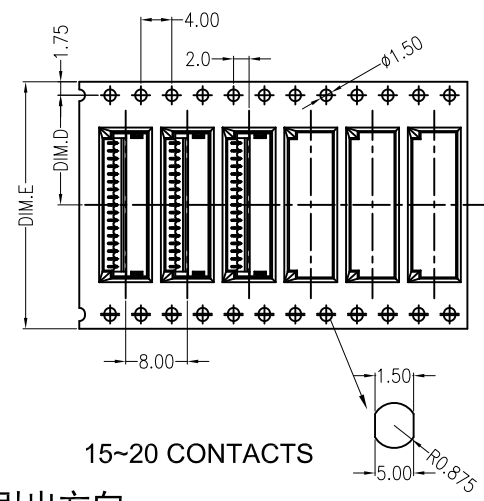

15~20 CONTACTS

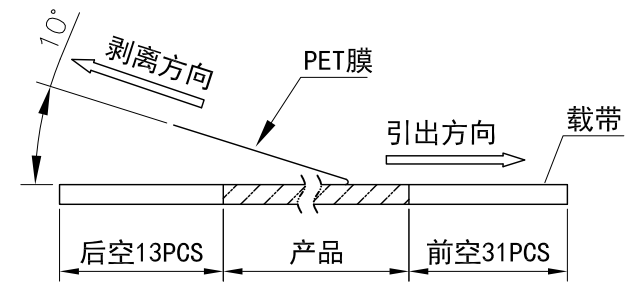

(PET膜剥离示意图)

产品引出方向

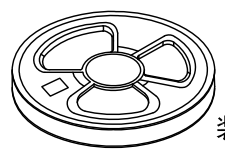
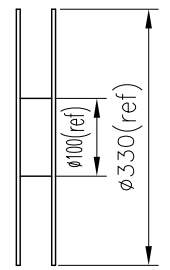
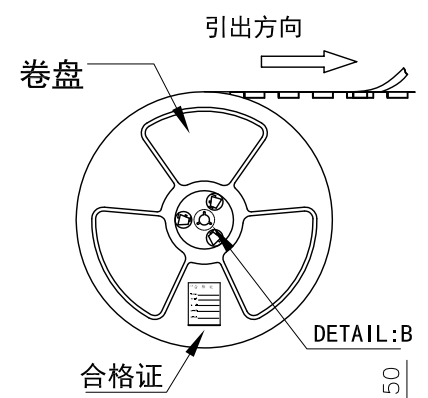

装*盘(参考列表一)

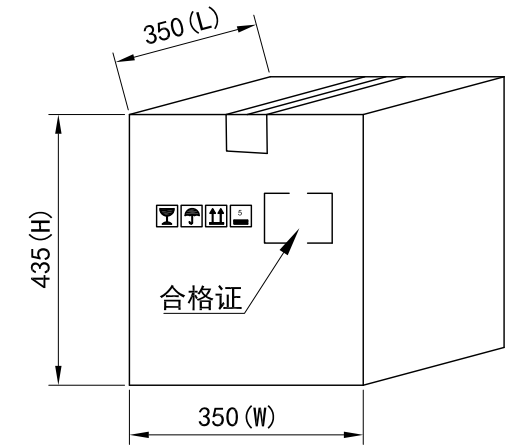
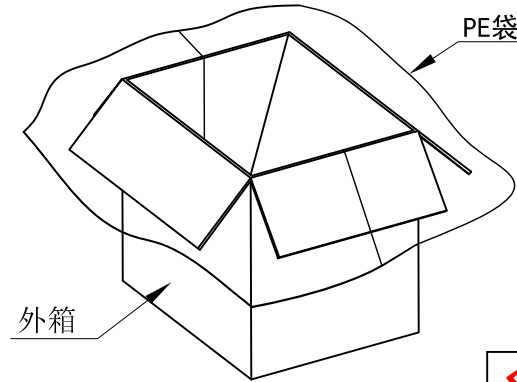

列表一

Circuits	DIM. D	DIM. E	Q'ty/Reel	Packing (Reel/Caton)
2 PIN	5.5	12	2500PCS	25/Reel
3~7PIN	7.5	16	2500PCS	20/Reel
8~15PIN	11.5	24	2500PCS	15/Reel
16~20PIN	14.2	32	2500PCS	11/Reel

包装说明:

- 把成品包入卷盘中，每盘装2500PCS，卷盘上贴上合格证，将装好产品的卷盘放进外箱中，外箱内先套一个大PE袋，外箱上贴贴上合格证。
- 所有材料有害物控制需符合RoHS标准。

东莞市高迪电子有限公司
DONG GUAN GAO DI ELECTRONICS CO., LTD

X.± 0.5	X.±'	USE: MANUFACTURE
.X± 0.3	.X±'	APPD: 王锋
.XX± 0.25	.XX±'	CHKD: 曾令青
--	--	DR: 蒋建银
	UNITS: mm	

TITLE:	
PART NO.: A1004AWR卷装规范	
DWG NO.: GCBZ-0819	
SCALE 1 : 1	SHEET 1 / 1